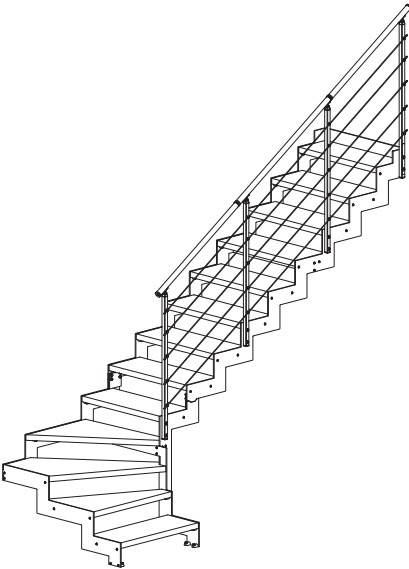

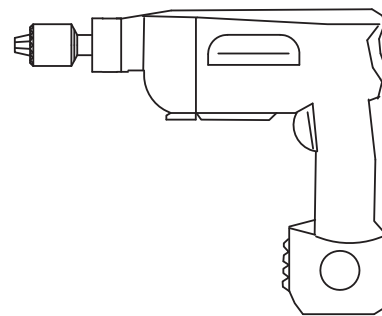
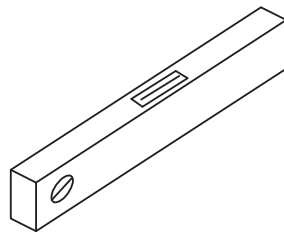
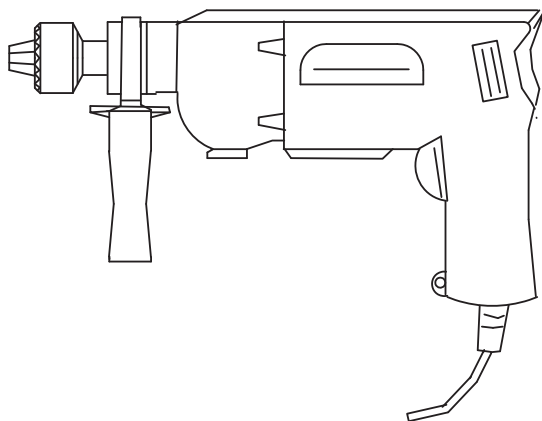
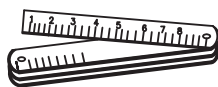
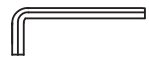
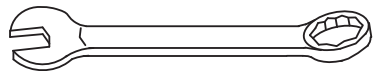
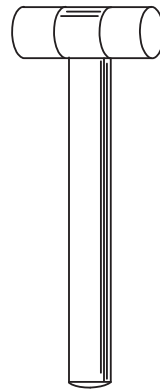
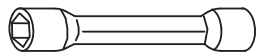
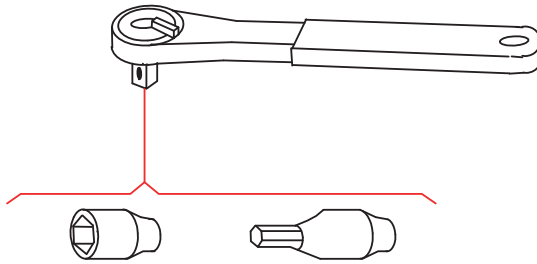
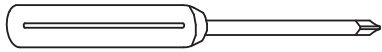
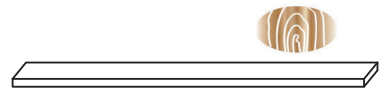
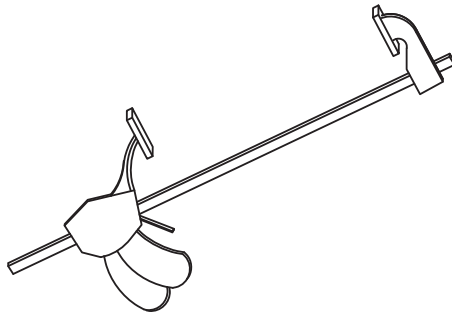





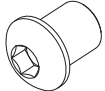


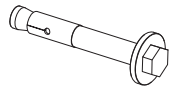
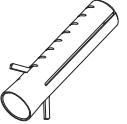






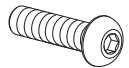
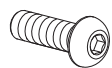

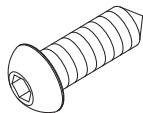
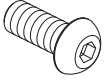
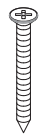

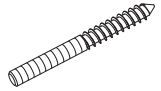
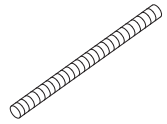

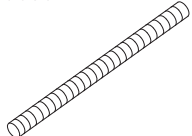


# Montageanleitung Stahlwangentreppe FX30

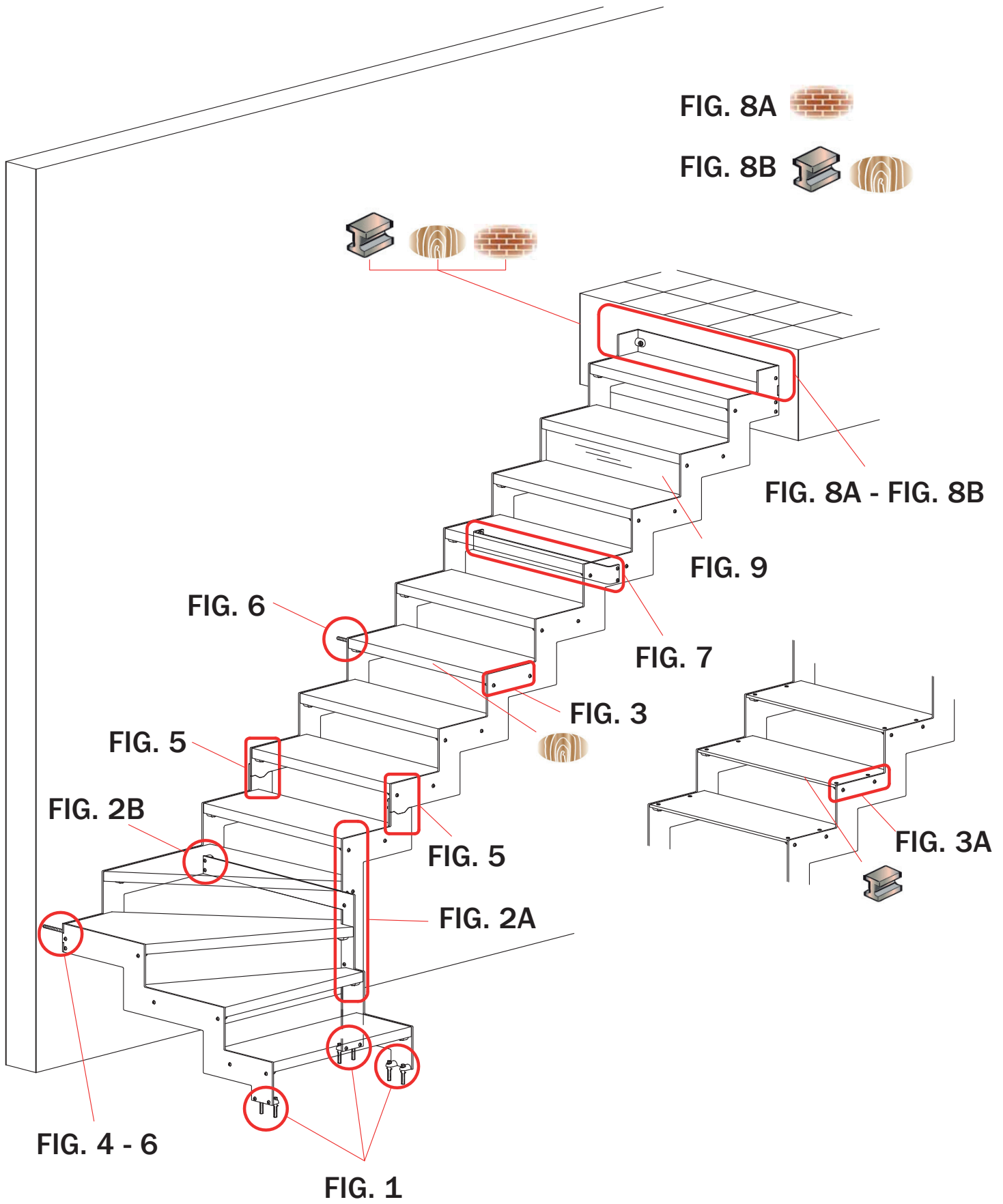




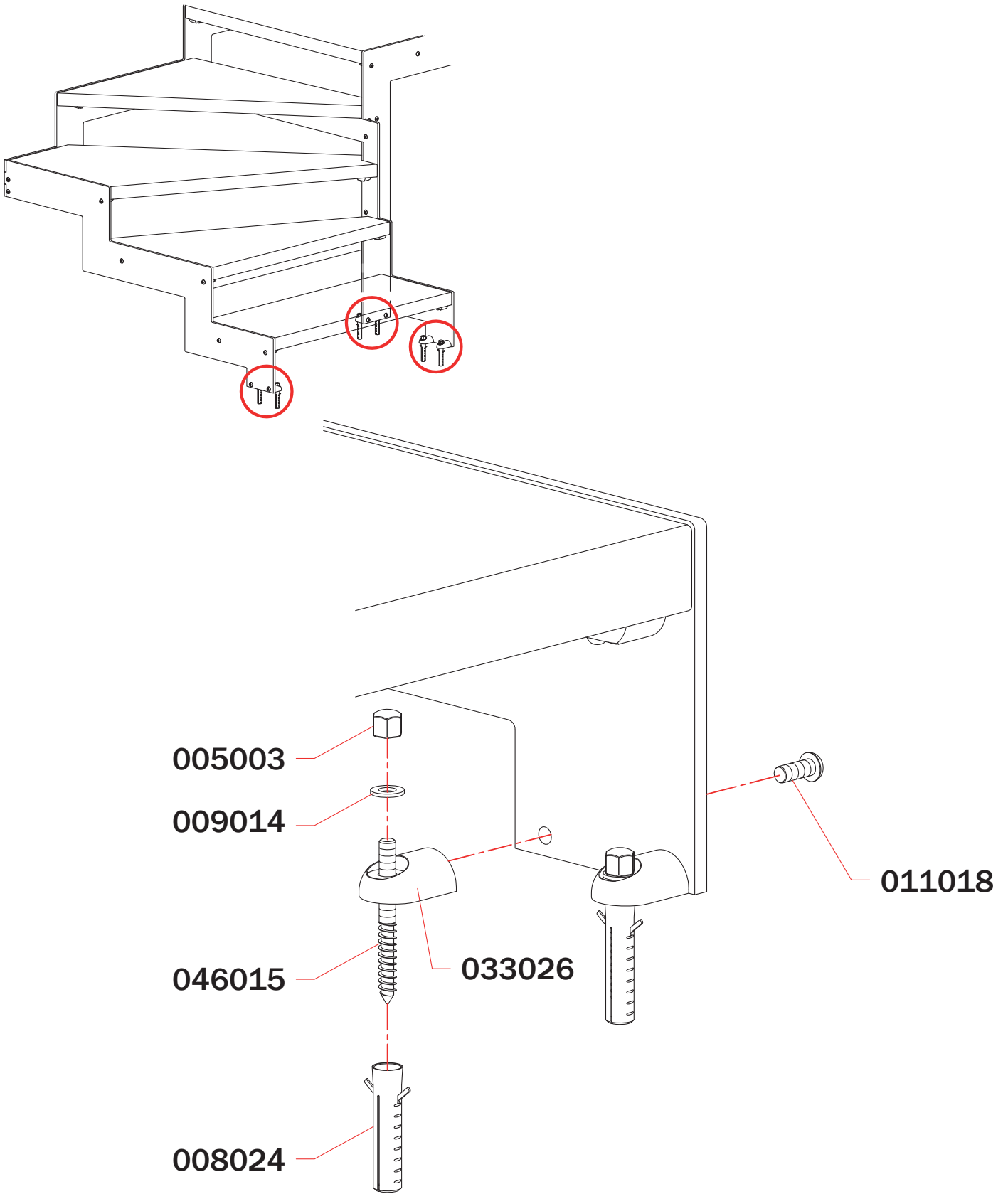
  
Ø 8 x 300 – 14 x 150 mm



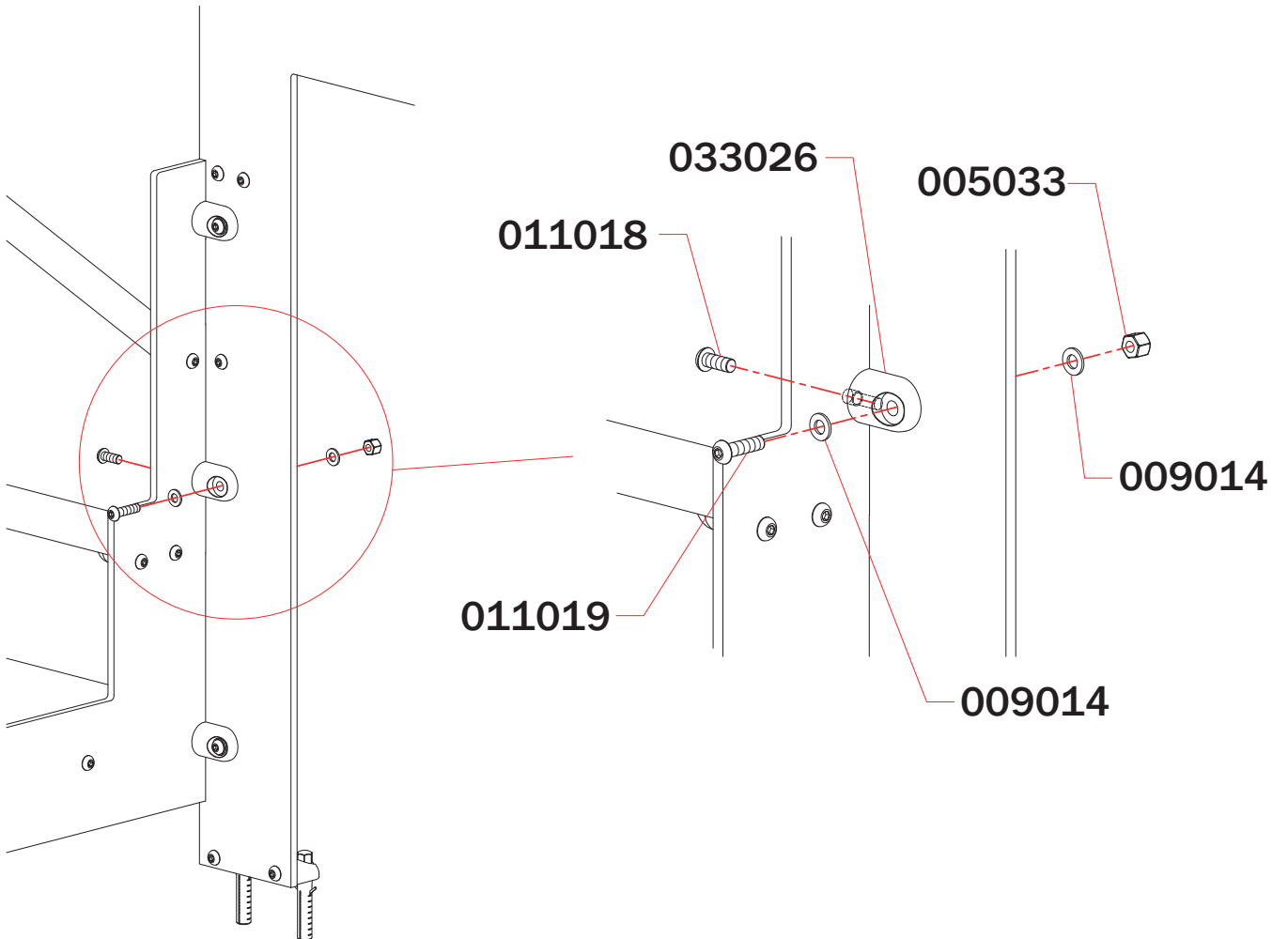
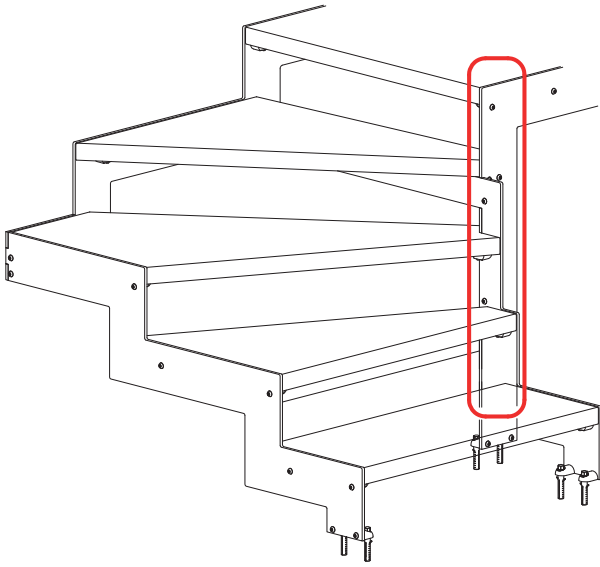
002060  VITE TRUC. TORX TPS 5X35 mm 5X35 mm TPS TORX PLYWOOD SCREW	004028  VITE CANN.M10 X 24 mm M10 x 24mm BOOK SCREW	004069  VITE CANN.M8 X 11,5 mm M8 X 11,5mm BARREL NUT	004072  VITE CANN.M12 X 20 mm M12 X 20mm BARREL NUT	005033  DADO CIECO M8 M8 CAP NUT
005053  DADO CIECO M10 M10 CAP NUT	008020  VITE ESP.18X120 mm 18x120mm EXPAND. SCREW	008024  TASSELLO NYLON D.12 mm D.12 mm NYLON DOWEL	009009  RANELLA 15 X 28 X 2.5 mm 15 X 28 X 2.5mm WASHER	009012  RANELLA 10 X 21mm 10 X 21mm WASHER
009014  RANELLA 8 X 17 mm 8 X 17 mm WASHER	009019  RANELLA 13 X 24 X 2,5 mm 13 X 24 X 2,5 mm WASHER	009022  RANELLA 17 X 30 X 3 mm 17 X 30 X 3 mm WASHER	011018  VITE TBCE M8 X 20 mm M8 X 20 mm TBCE SCREW	011019  VITE TBCE M8 X 30 mm M8 X 30 mm TBCE SCREW
011020  VITE TBCE M8 X 25 mm M8 X 25 mm TBCE SCREW	011053  VITE TBCE TRUC.6,4 X 40 mm 6,4 X 40 mm TBCE SCREW	011054  VITE TBCE TRUC.10 X 35 mm 10 X 35 mm TBCE SCREW	011061  VITE T.B.C.E. M12 X 30 mm M12 X 30 mm TBCE SCREW	012014  VITE TRUC. TPS 5X50 mm 5X50 mm TPS PLYWOOD SCREW
033026  SUPPORTO GRADINO TREAD SUPPORT	046015  MOZZ.FIL.LE/FE M8 X 80 mm M8X80mm THREADED BAR	046021  MOZZ.FIL. M12 X 200 mm M12X200mm THREAD.L BAR	046056  MOZZ.FIL.LE/FE M 10 X 140 mm M 10 X 140 mm THREADED BAR	046060  BARRA FIL. M10 X 1500 mm M10X1500mm THREAD. BAR
 DIST.LAT.42x42x205 mm 42x42x205mm LAT. SPACER	 Ø48 mm Ø48 mm			



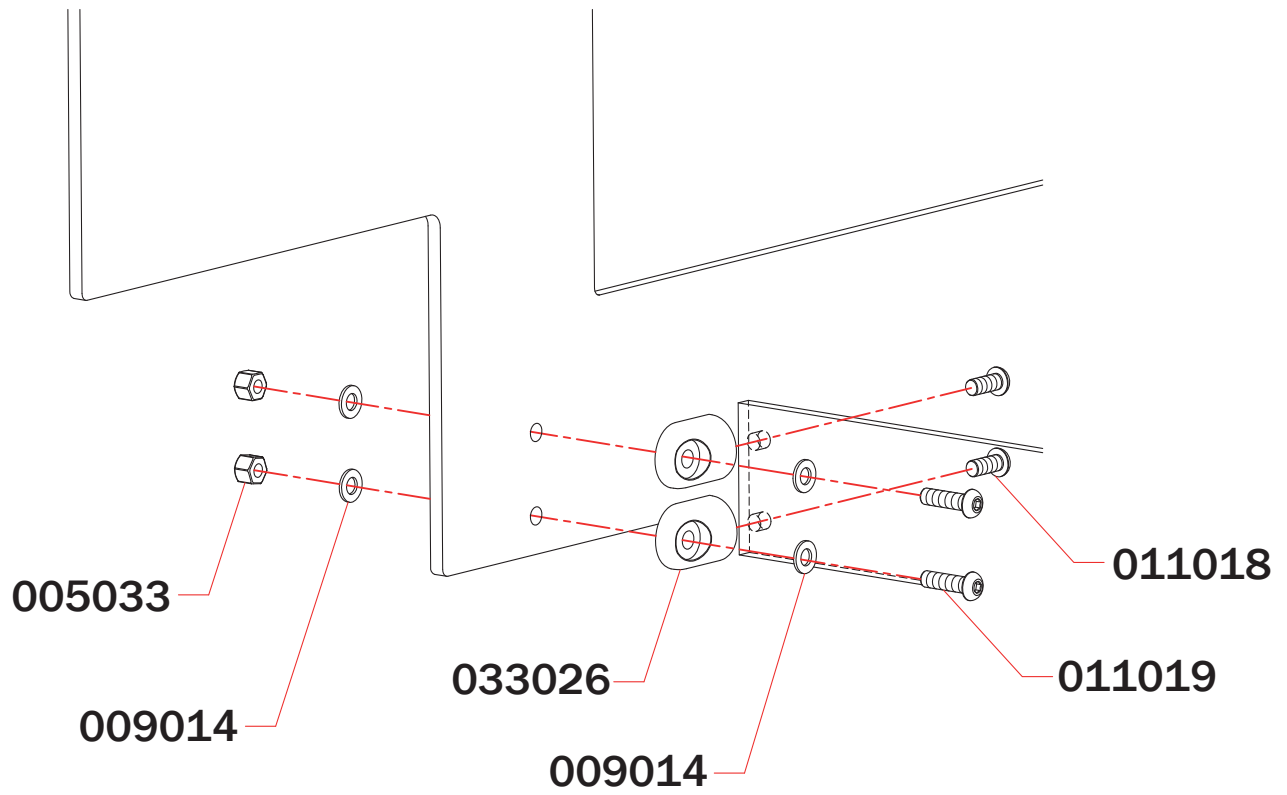
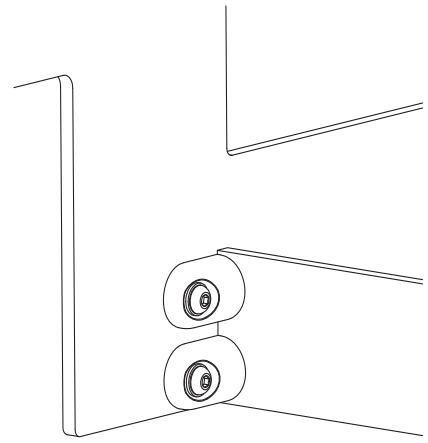
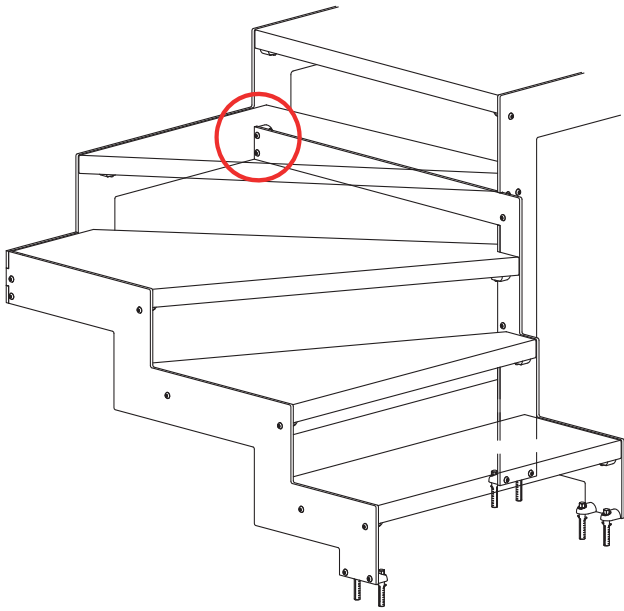
**FIG. 1**



**FIG. 2 A**

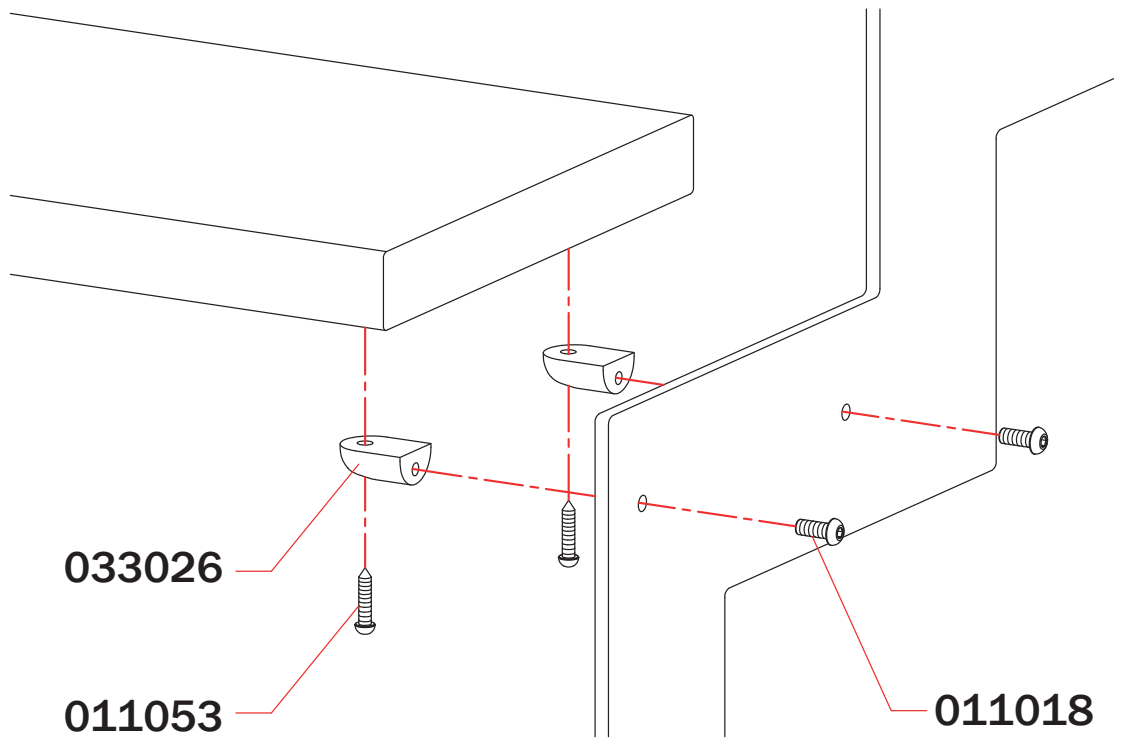
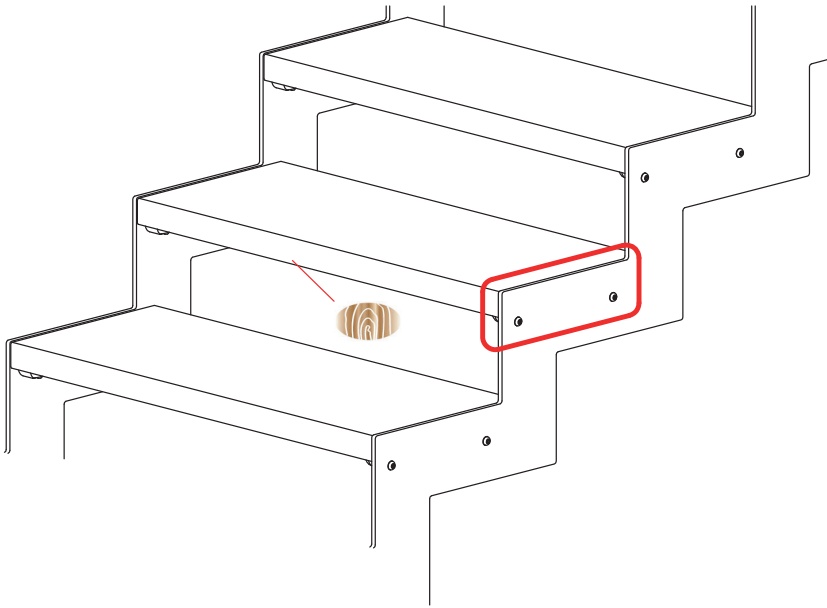


**FIG. 2 B**

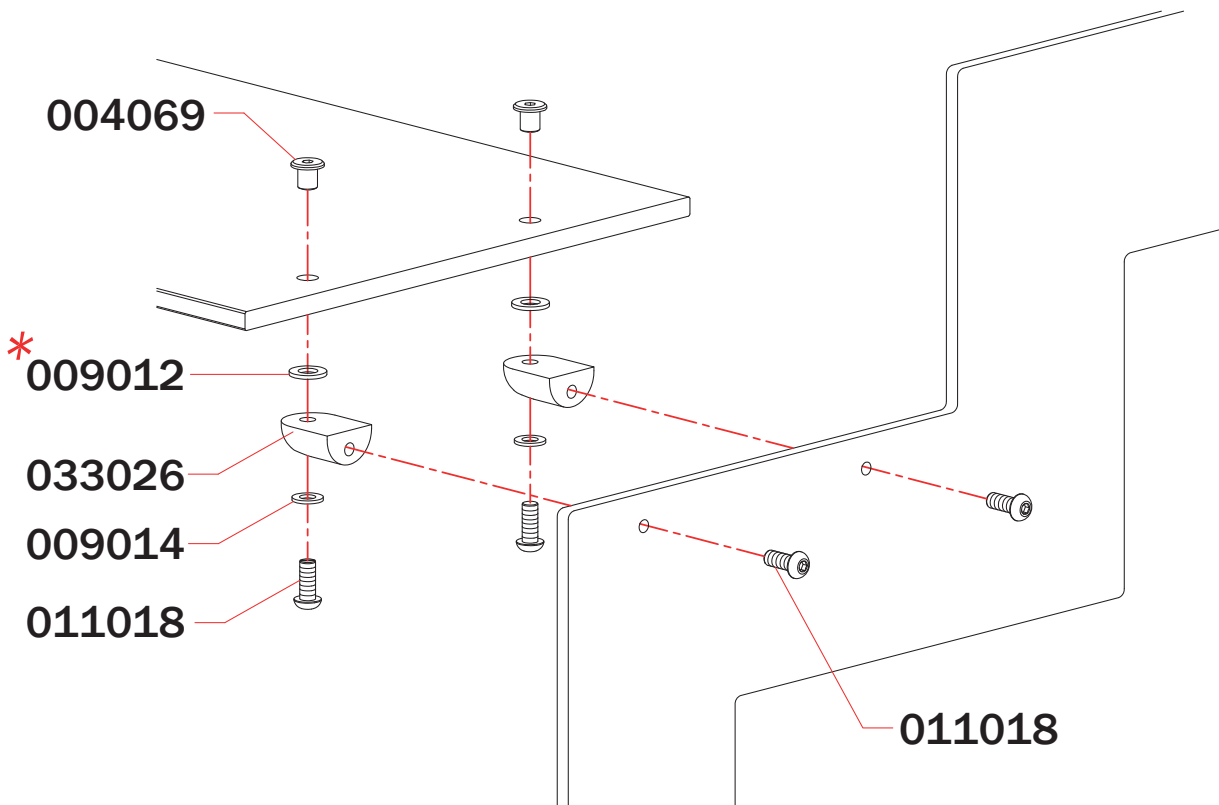
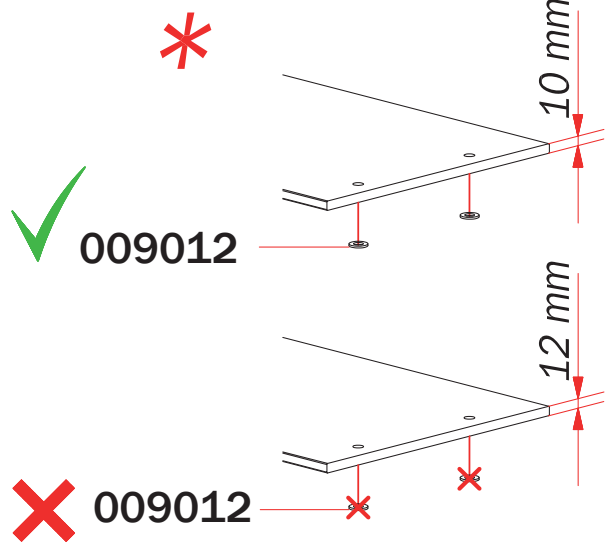
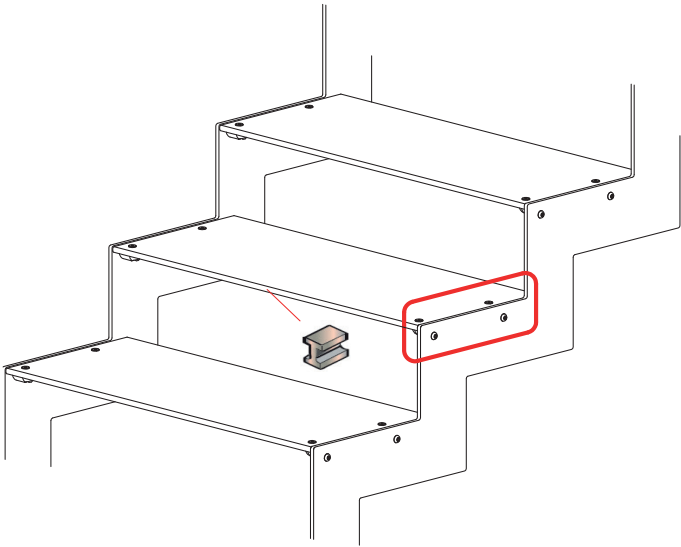




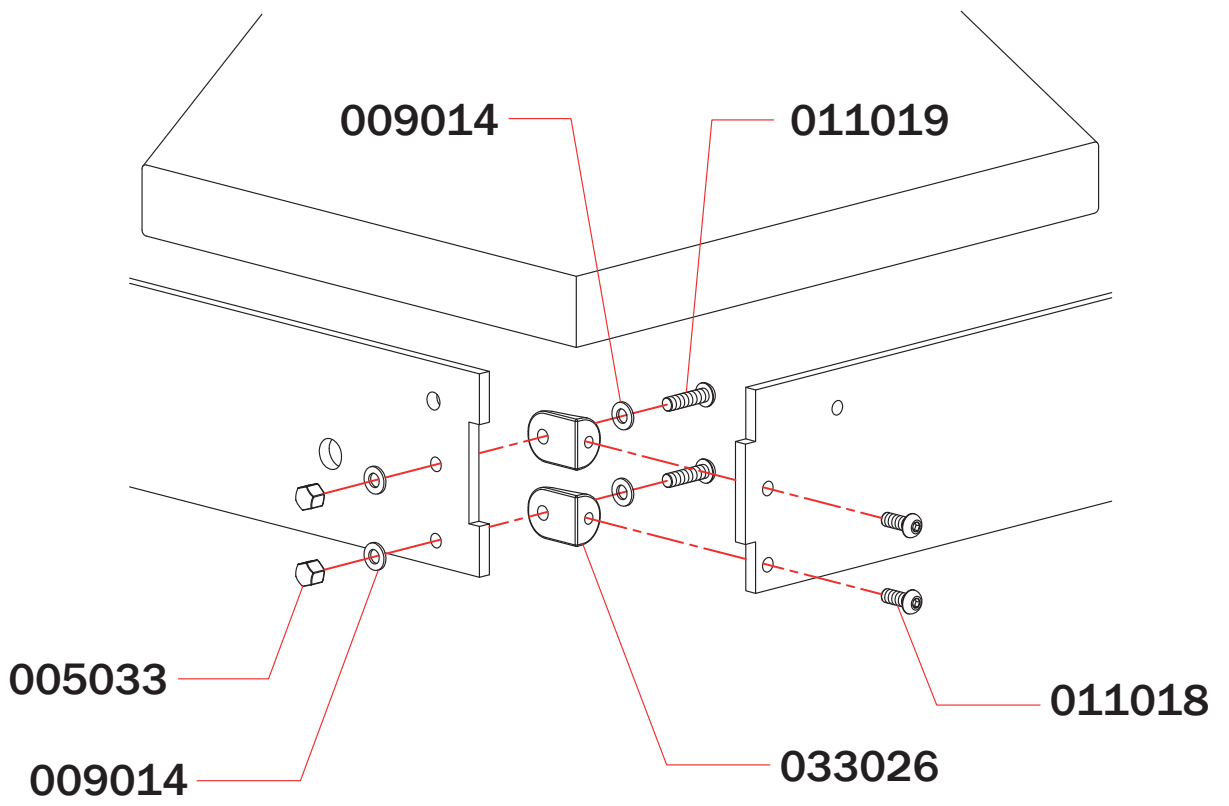
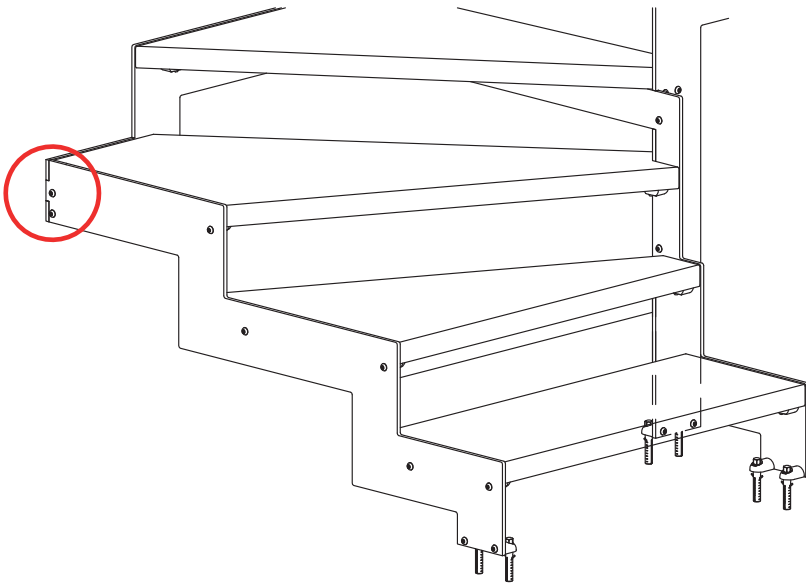
**FIG. 3**



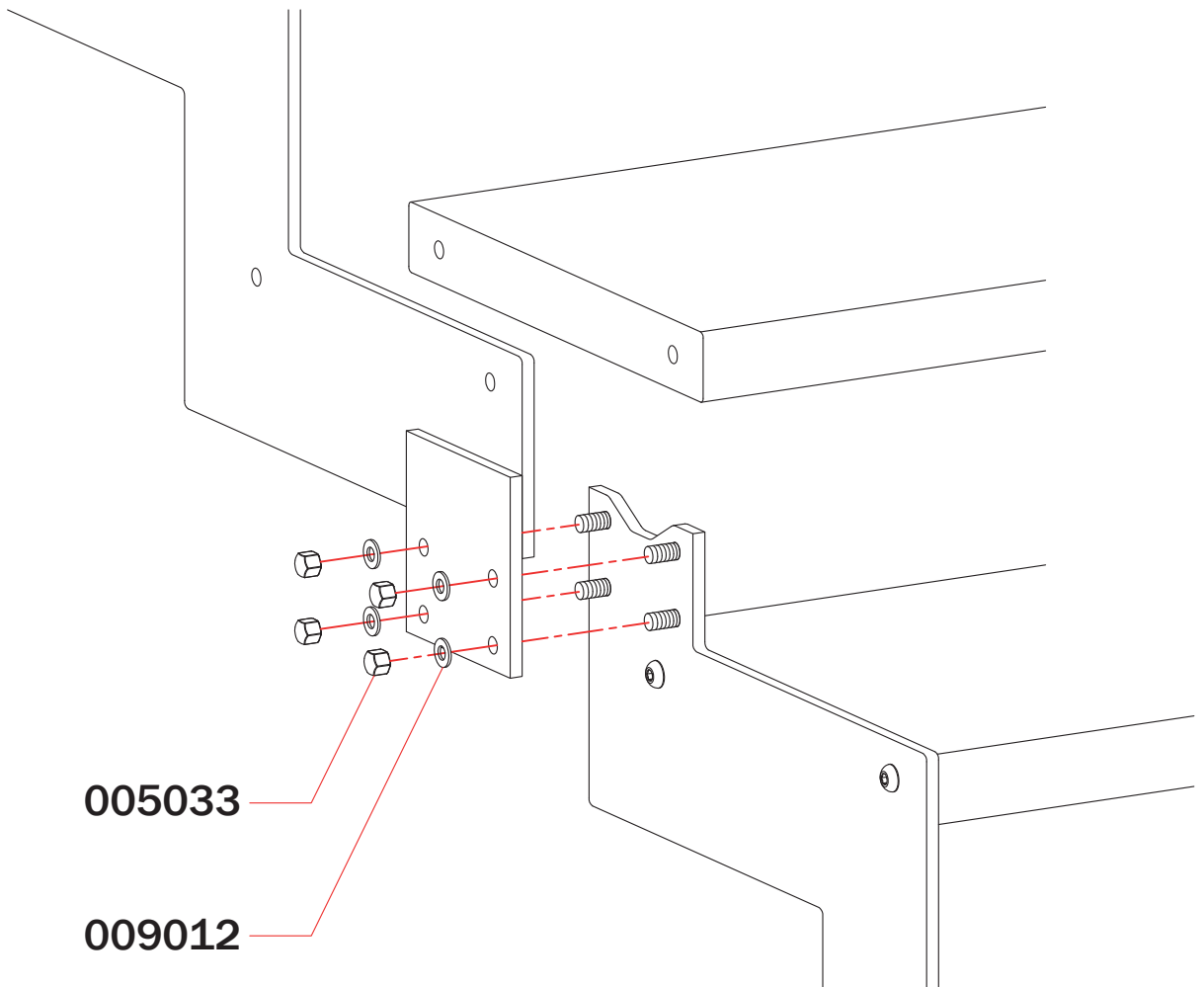
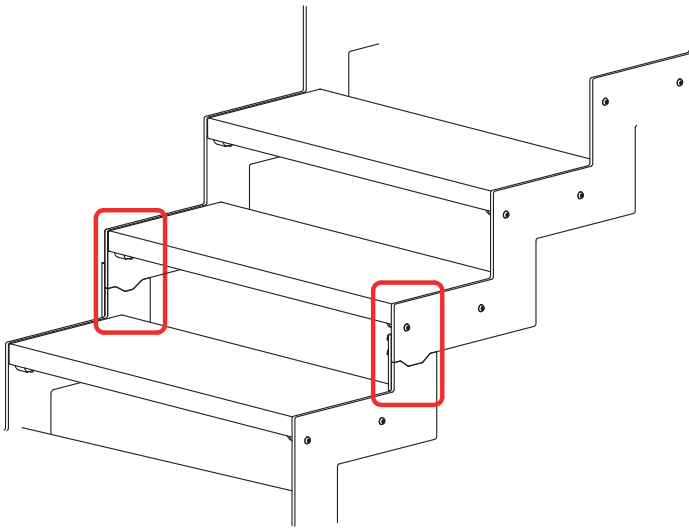
**FIG. 3 A**



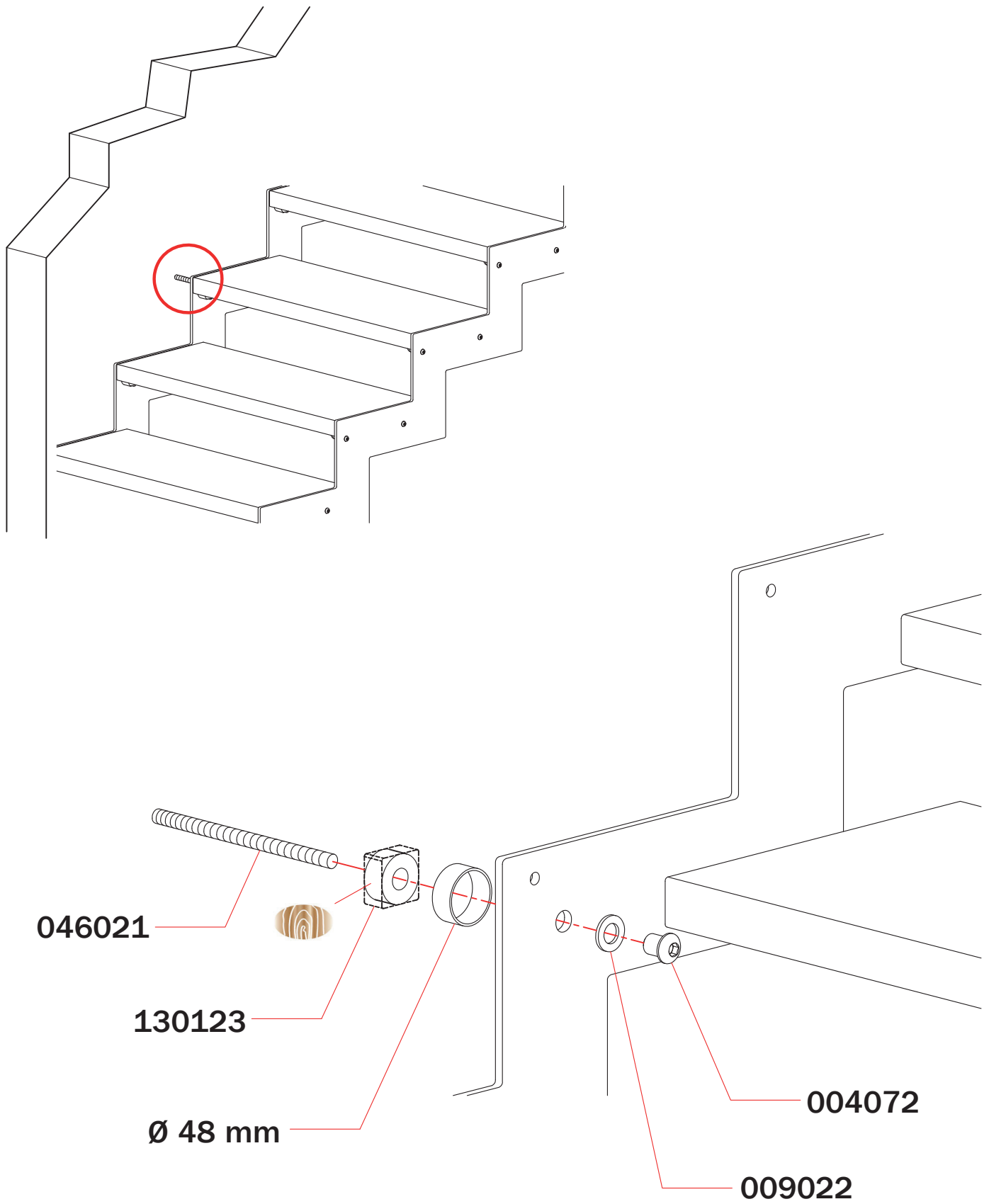
**FIG. 4**



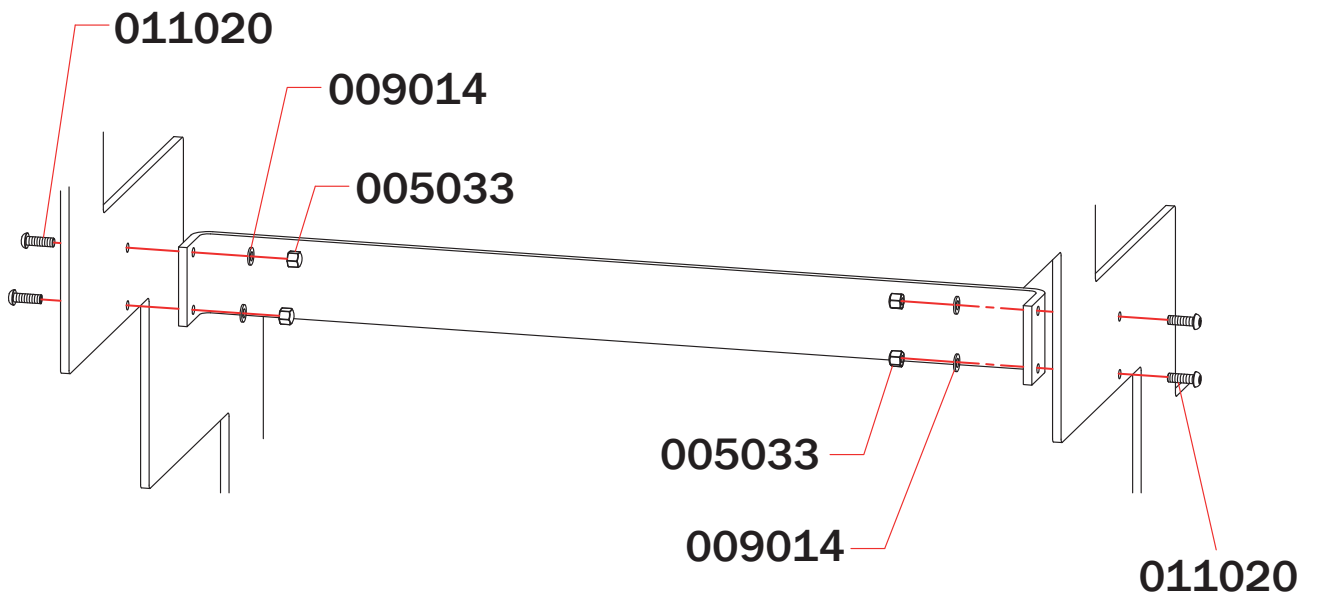
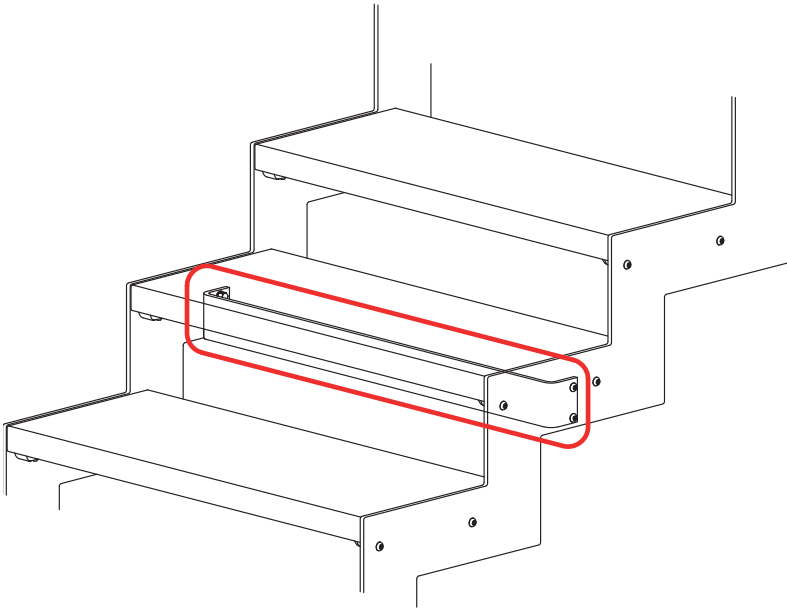
**FIG. 5**



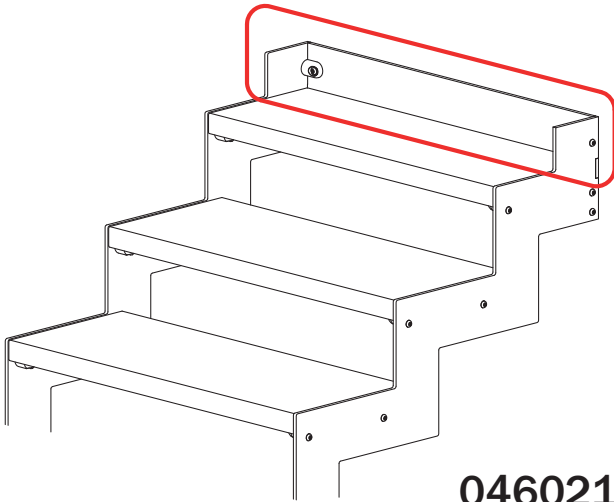
**FIG. 6**



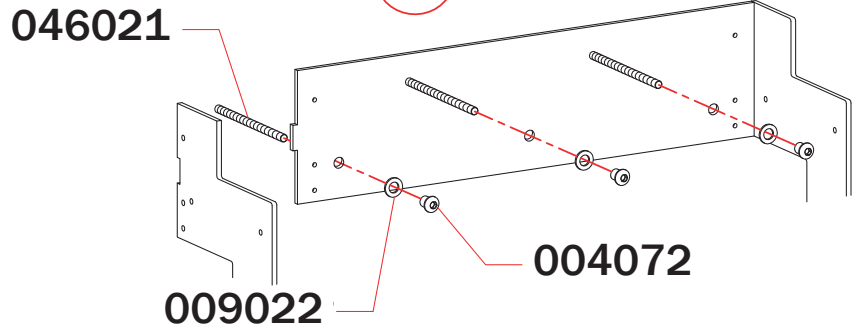
**FIG. 7**



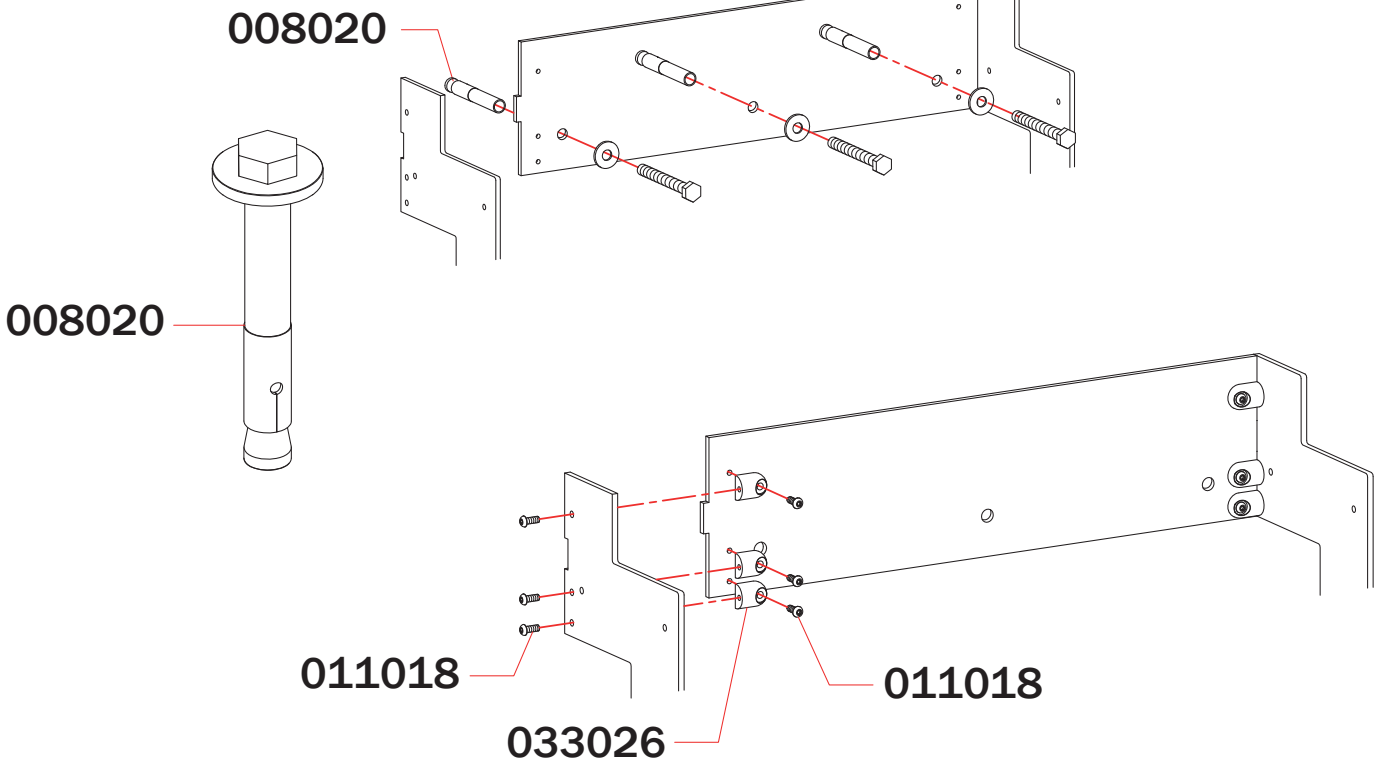
**FIG. 8 A**



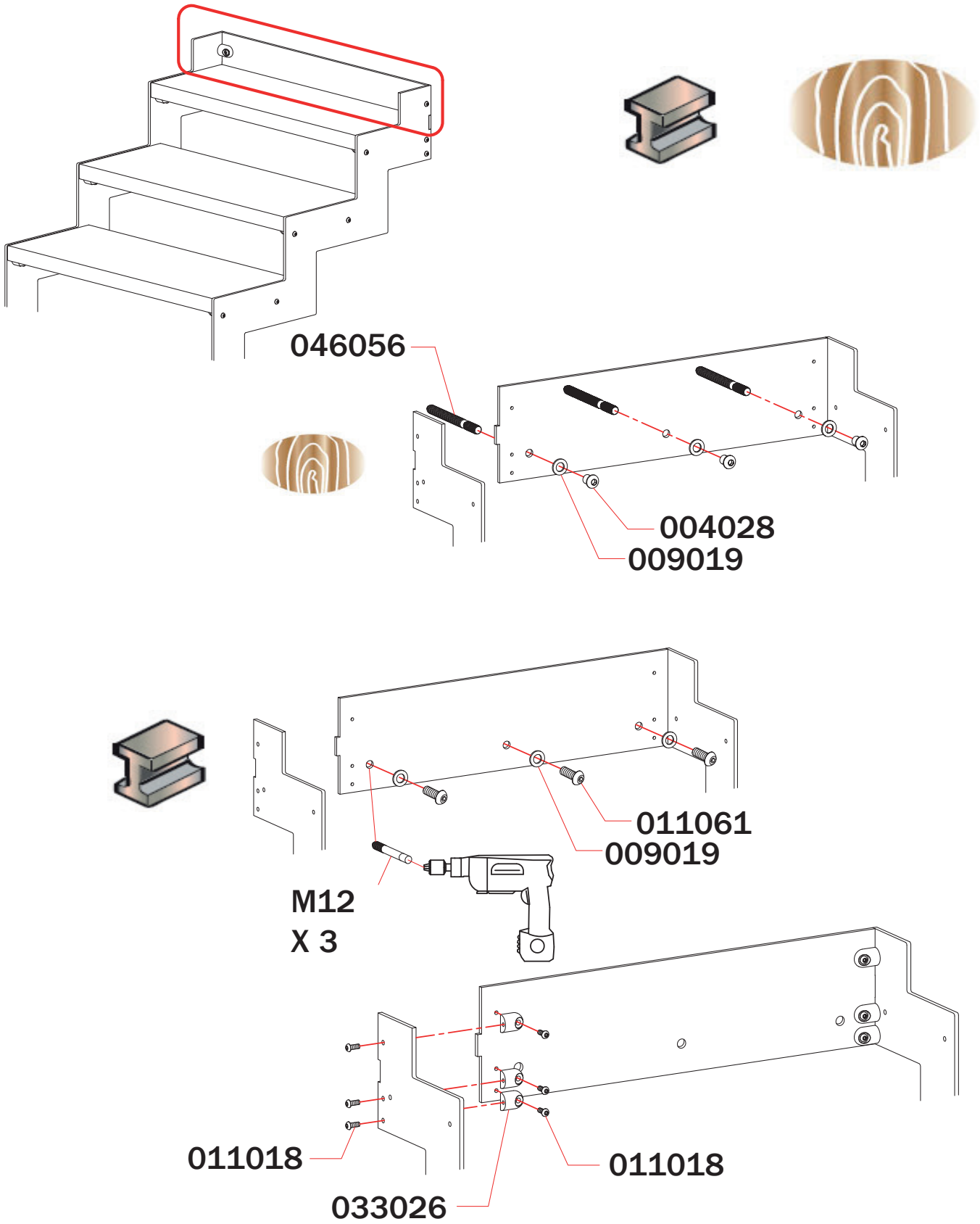
**1**



**2**

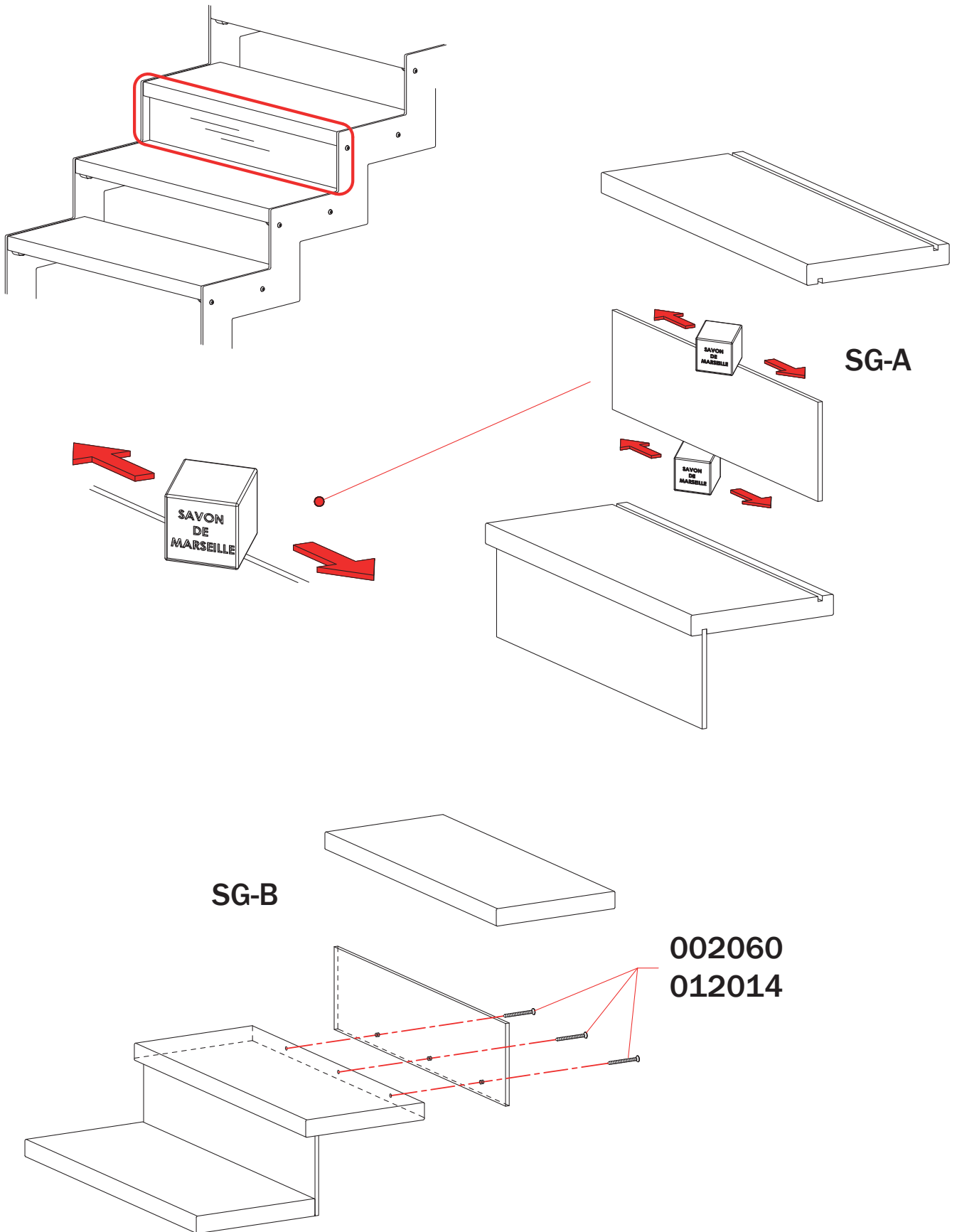


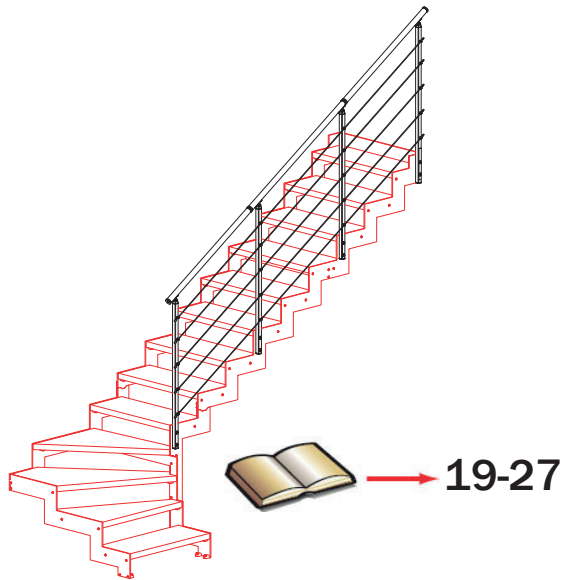
**FIG. 8 B**

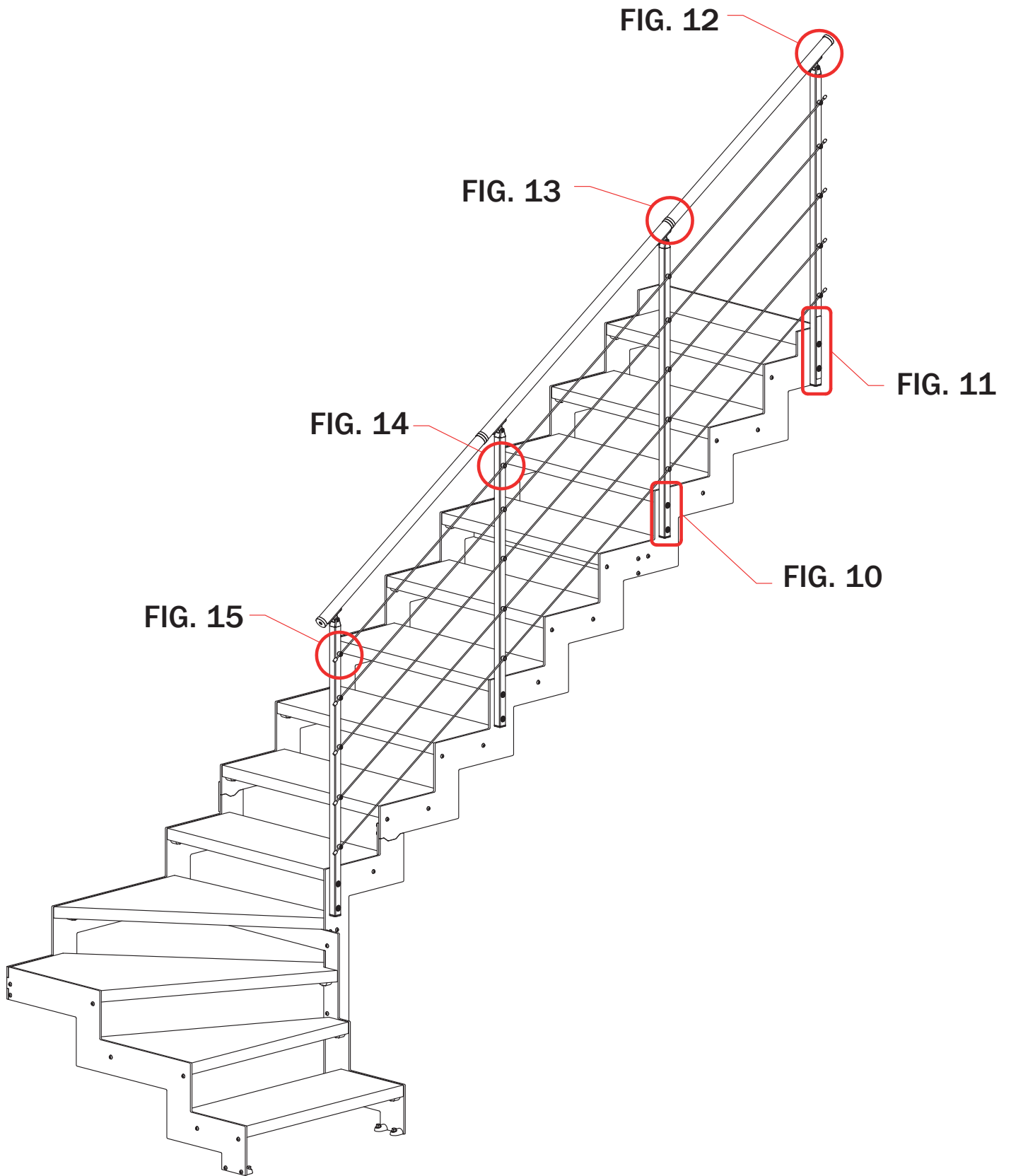






**FIG. 9**

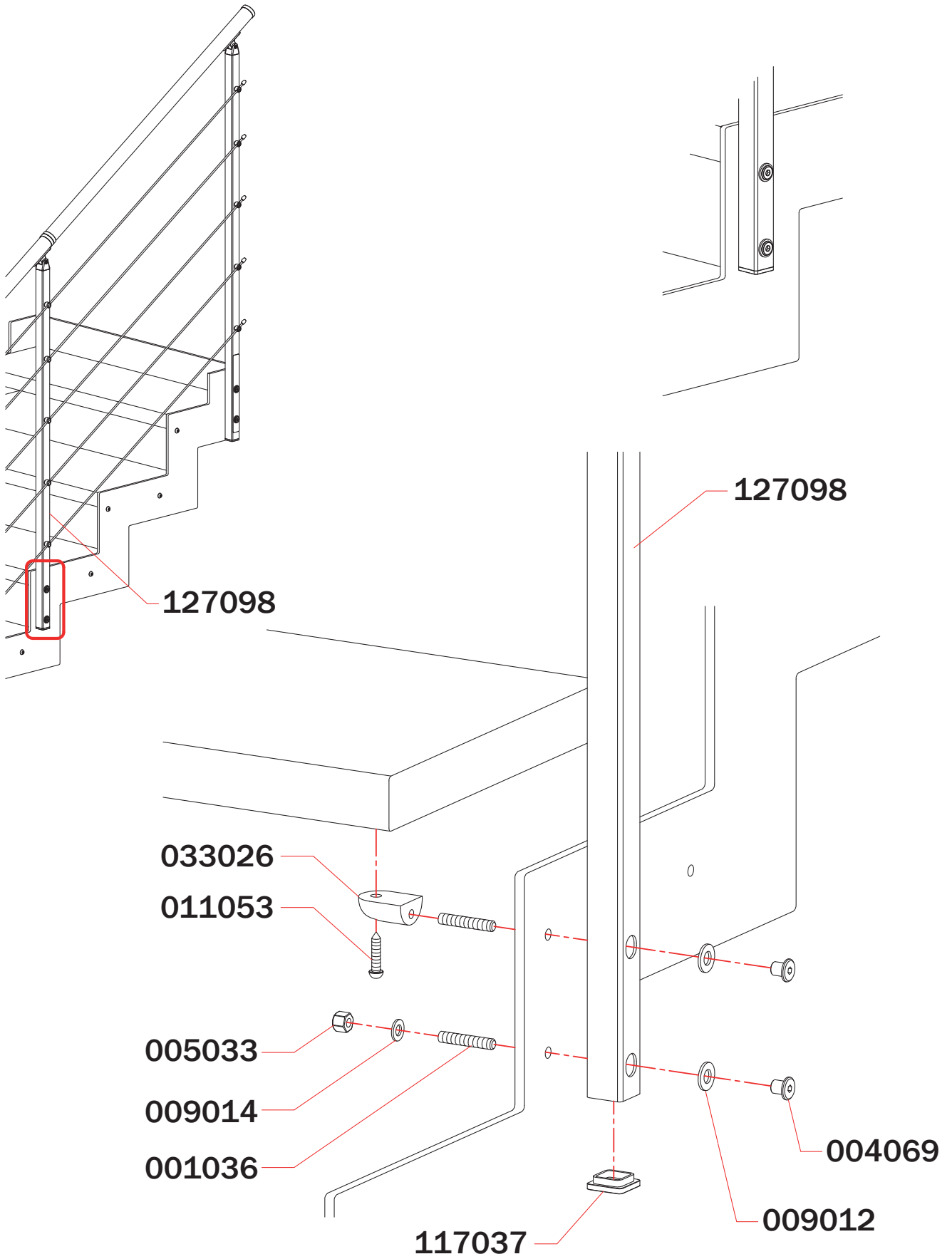




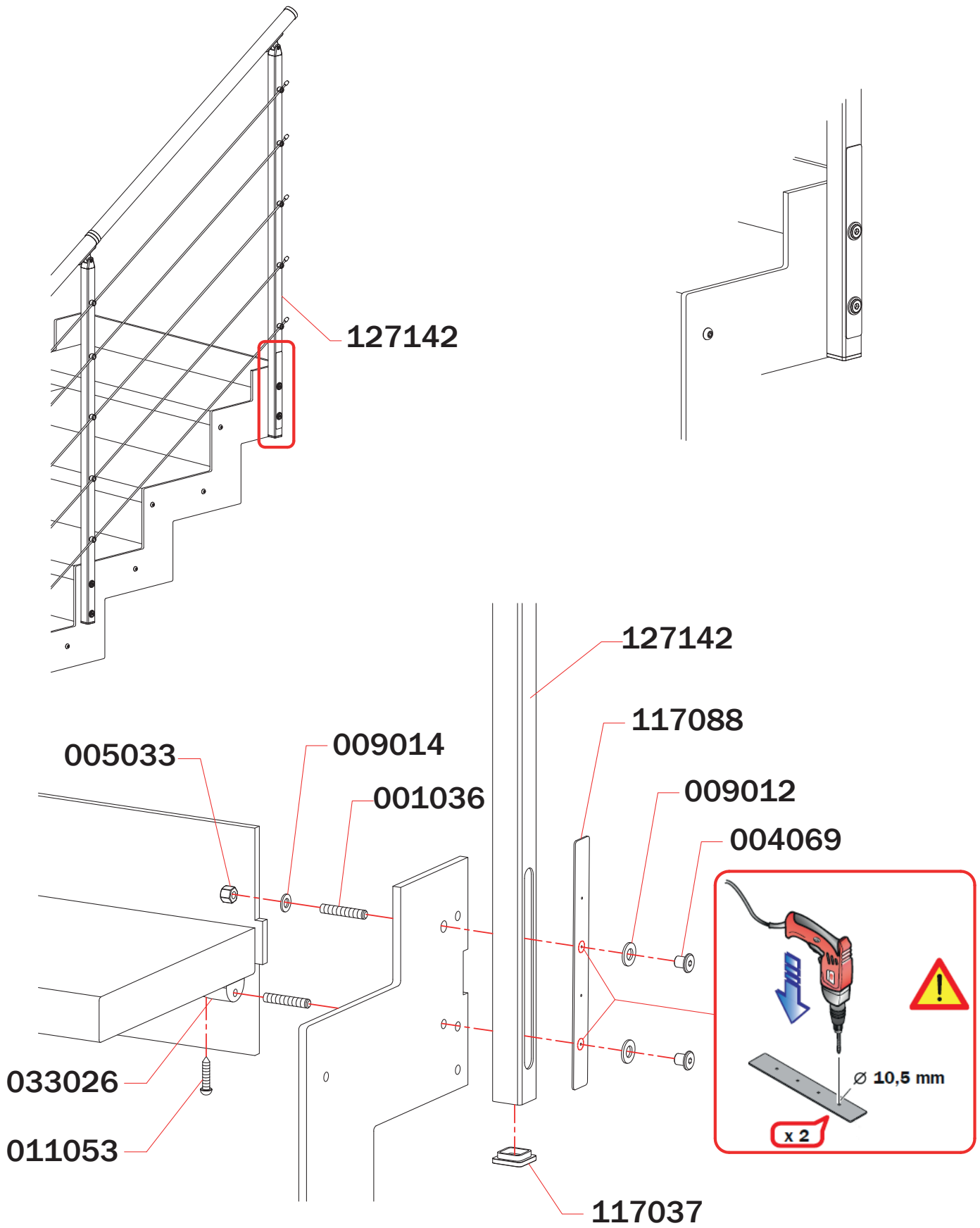


001011  GRANO M4 X 4 P.COPPA Z.B. M4X4 CONV.HEAD GRUB SCR. 002050	001028  SFERA ACCIAIO D. 6,35mm D. 6,35mm STEEL SPHERE 004028	001036  GRANO M8 X 30 P.COPPA Z.B. M8X30 CONV.HEAD GRUB SCR. 004069	001037  GRANO M8 X 25 P.COPPA Z.B. M8X25 CONV.HEAD GRUB SCR. 005011	002024  VITE AUT.T.B. T/C 3,5 X 16 Z.B. T/C 3.5X16 AUTOTH.WHITE SCR. 005033
 VITE PERF.TPS T/C 4,2 X 16 Z.B. T/C 4,2 X 16 TPS PERFOR. SCR. 005035	 VITE CANN.M10 X 24 mm M10 x 24mm BOOK SCREW 009009	 VITE CANN.M8 X 11,5 mm M8 x 11,5 mm BOOK SCREW 009012	 DADO M8 Z.B. M8 WHITE ZINK NUT 009014	 DADO CIECO M8 M8 CAP NUT 011088
 DADO M6 N.O. M6 OPAQUE NICHEL NUT 013030	 RANELLA 15 X 28 X 2.5mm 15X28X2.5mm WASHER 013031	 RANELLA 10 X 21mm 10 X 21mm WASHER 031098	 RANELLA 8 X 17 mm 8 X 17 mm WASHER 031168-031170-031172	 VITE TBCE M6 X 25 Z.B. M6X25 TBCE WHITE ZINK SCR. 031169-031171-031175
 VITE TPSEI M6 X 50 Z.B. TPSEI M6X50 WHITE ZINK SCR. 033055	 VITE T.E. M8 X 100Mm Z.B. M8X100mm T.E. Z.K WH.SCREW 033055	 FERMO CILINDRO PASSA CAVO CYLINDER CABLE HOLDER 034042	 UNIONE CORRIM. D.40 X 1,5 D.10X1.5 HANDRAIL JOINT 034056	 CONO ESPAN.CORR. D.40 X 1,5 D.40X1.5 HANDR.EXPAND.CONE 046015
 STAFFA FISS.CORRIM.D.40 D.40 HANDRAIL,FAST. BRACKET 117037	 CILINDRO PASSA TONDINO BAR FASTENING CYLINDER 117088	 FINALE PROTEZIONE CAVO CABLE END PROTECTION 124063	 CAPP.PALETTO QUADRO 30 X 30 30X30 SQ.BALUST.UPPER FAST. 127098	 MOZZ.FIL.LE/FE M 8 X 80 mm M 8 X 80 mm THREADED BAR 127142
 TAPPO INF.PALETTO 30 X 30 30X30 BALUST.LOWER CAP 142031	 PIASTRINO COPRI ASOLA LOOP COVER PLATE	 TAPPO LEGNO D.34.5 X 4mm D.34.5 X 4mm WOOD CAP	 PALETTO 30X30 H1065 30X30 H1065 BALUSTER	 PALETTO 30X30 H1145 30X30 H1145 BALUSTER
 CORR.METALLO D.40 L.1185 D.40 L.1185 METAL HANDRAIL				

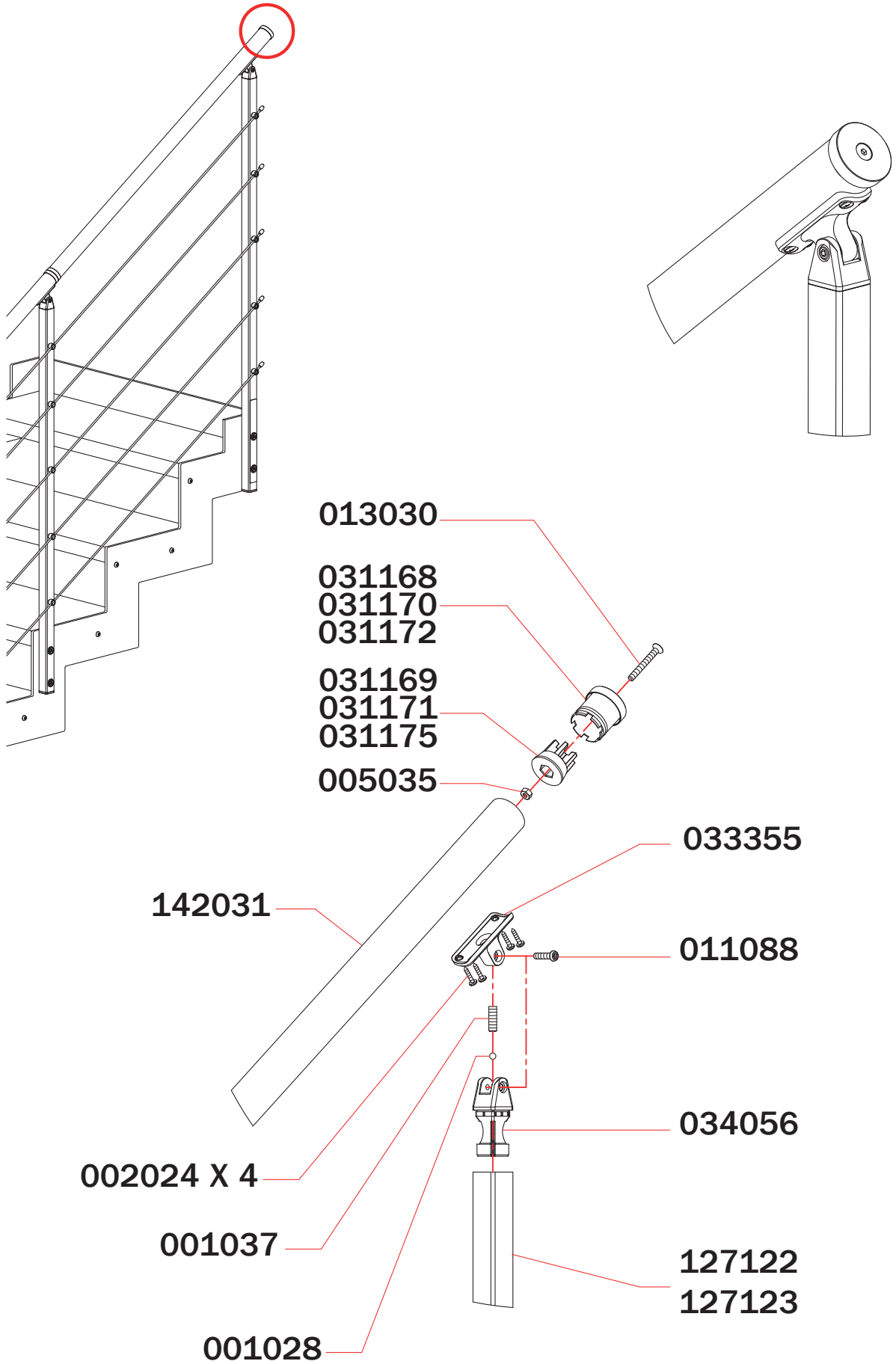
**FIG. 10**



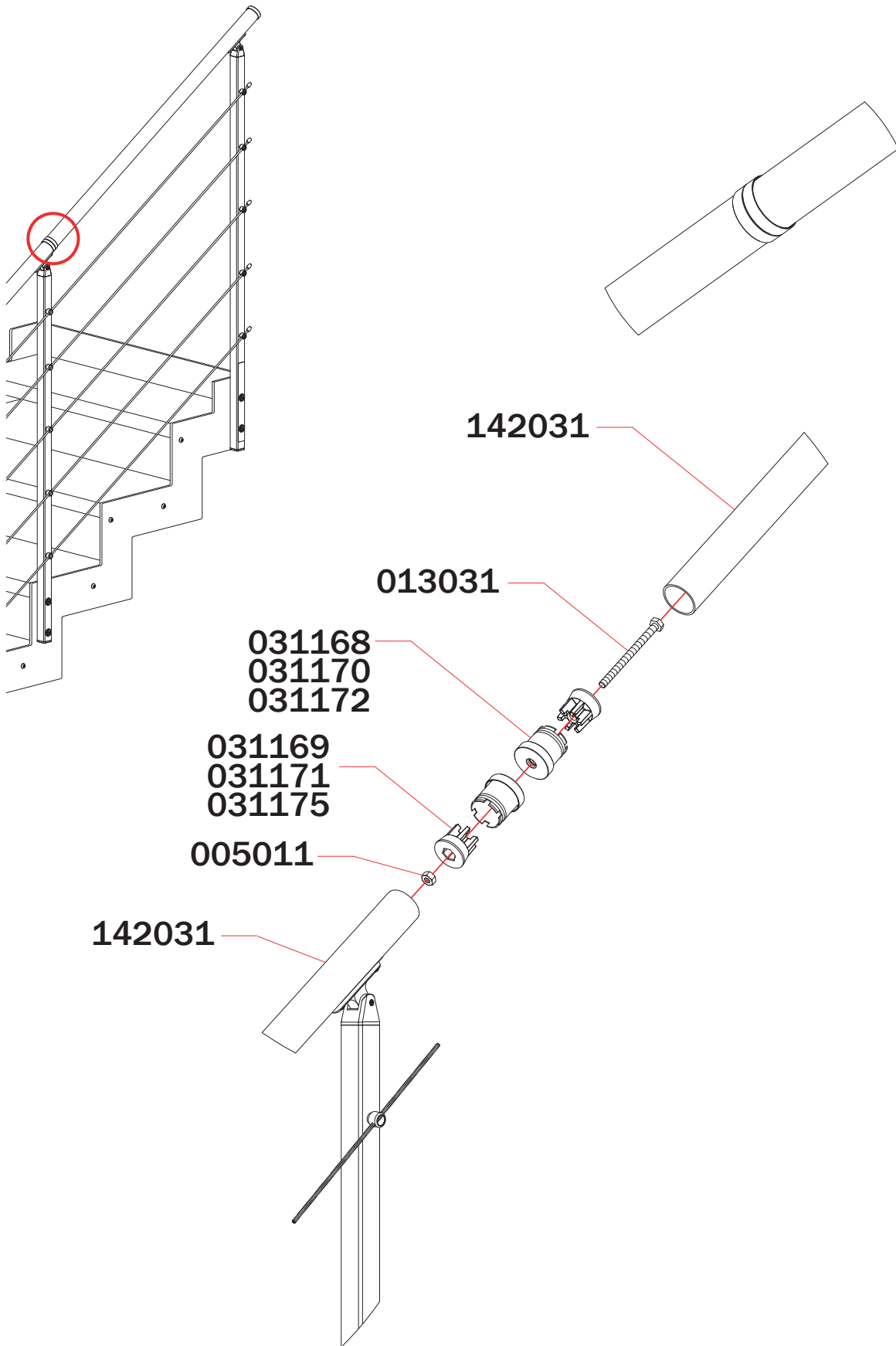
**FIG. 11**



**FIG. 12**

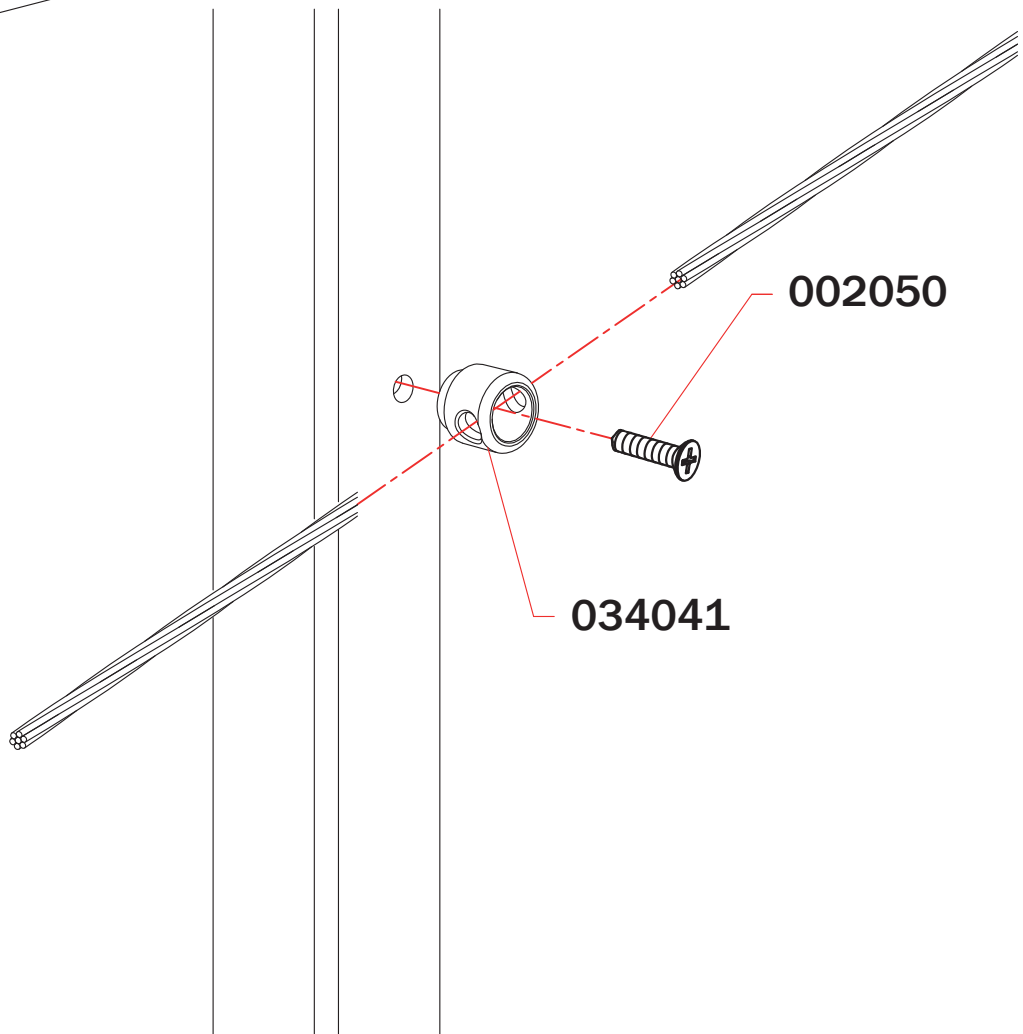
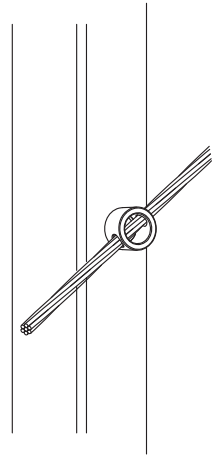
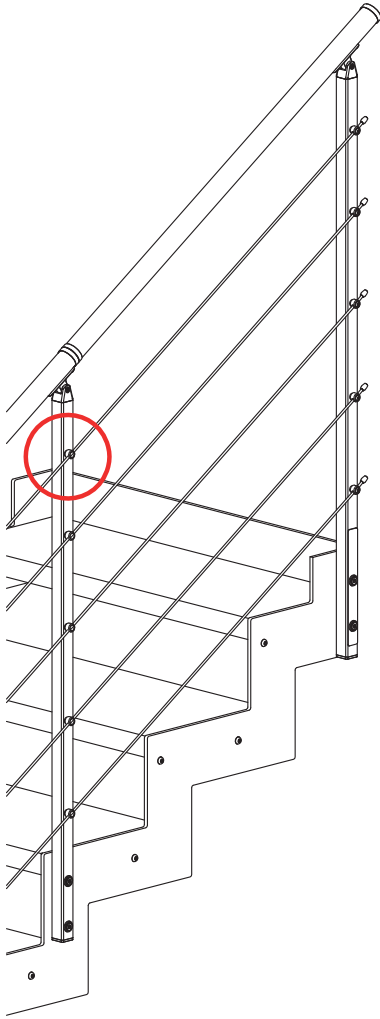


**FIG. 13**





**FIG. 14**



**FIG. 15**

