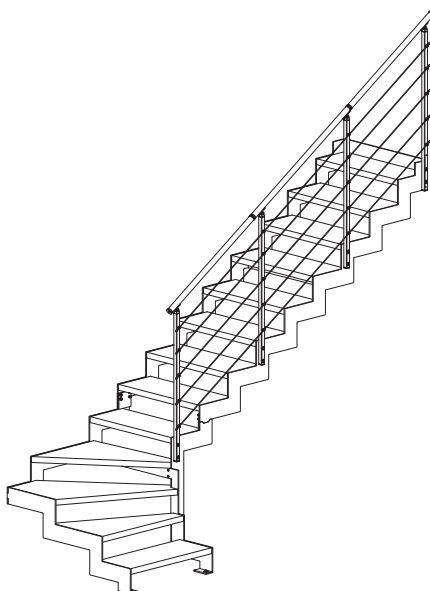
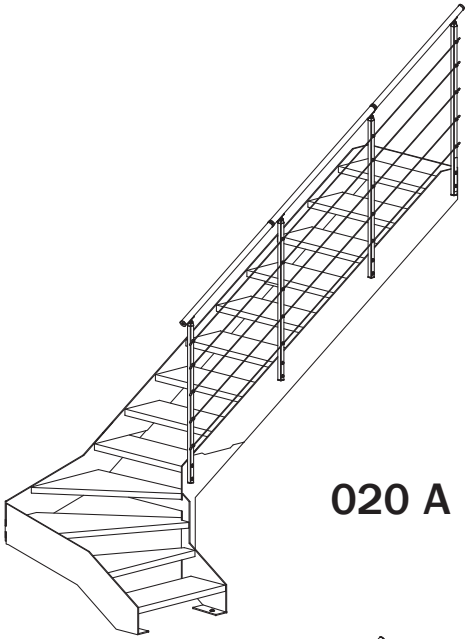
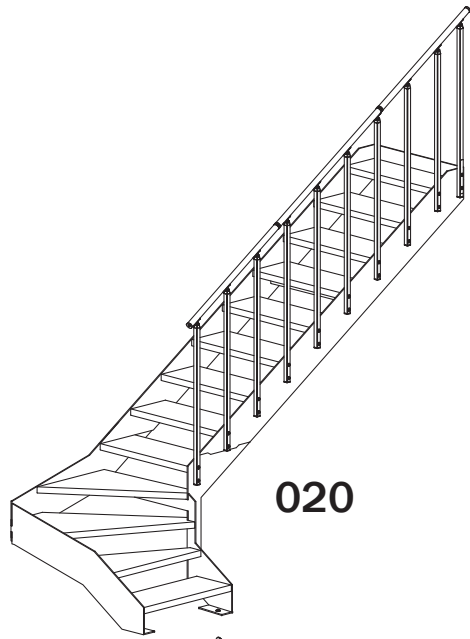


# Montageanleitung Stahlwangentreppe Sean FX30

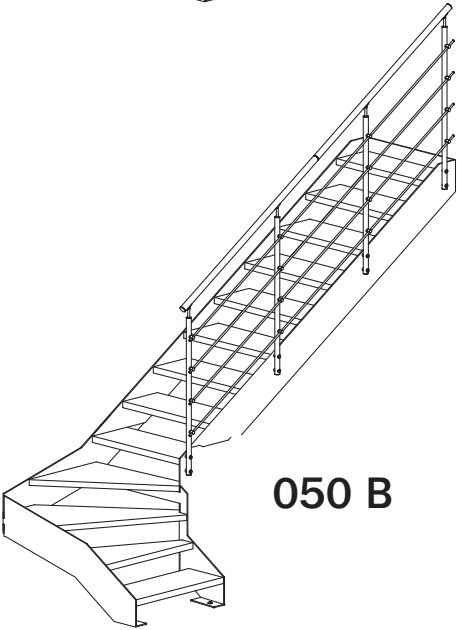




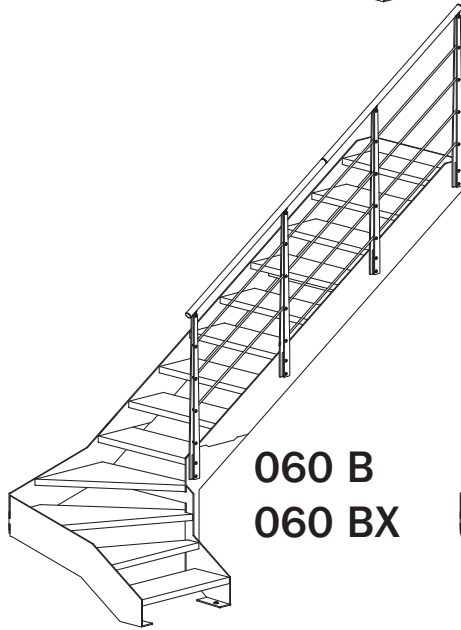
**020 A**



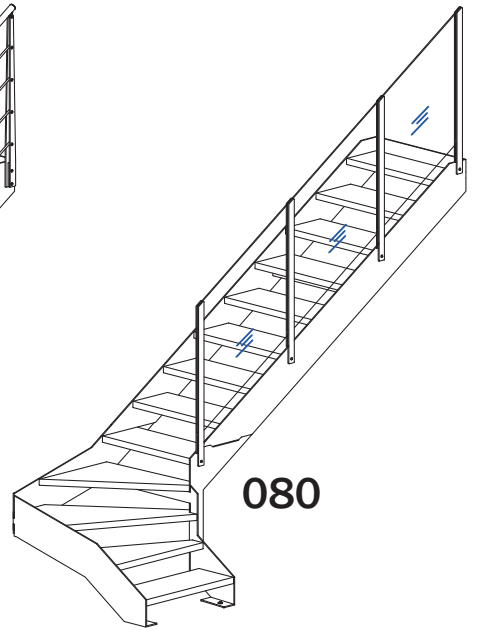
**020**



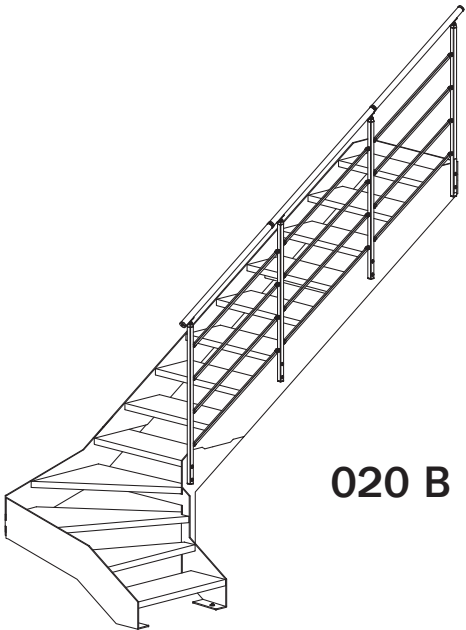
**050 B**



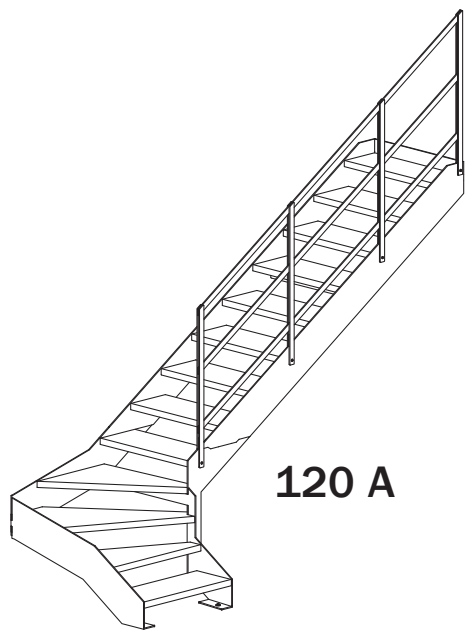
**060 B  
060 BX**



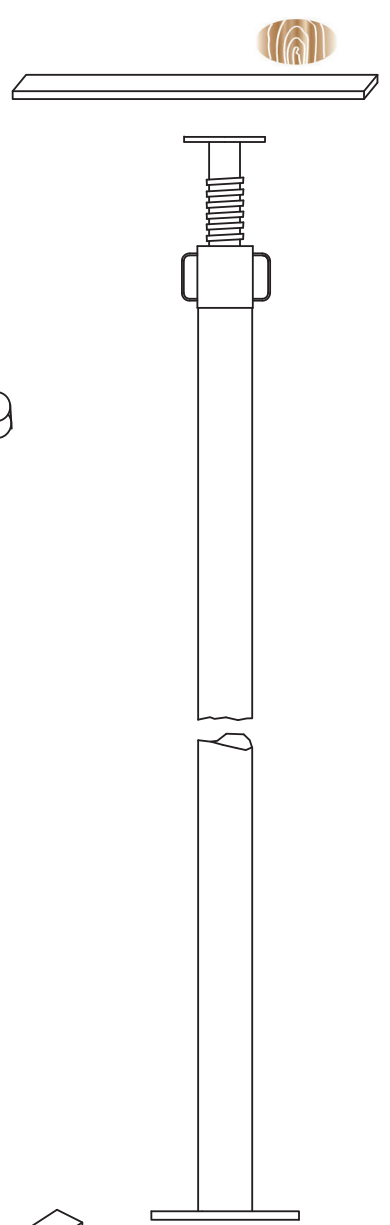
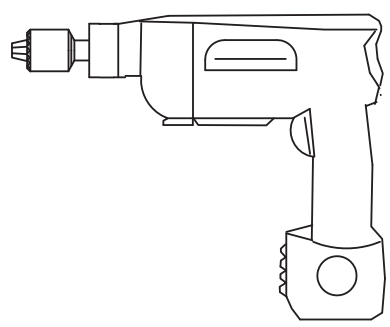
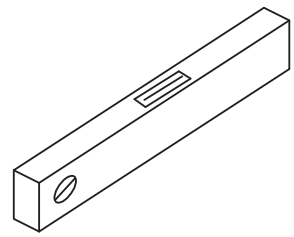
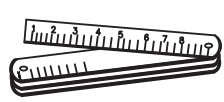
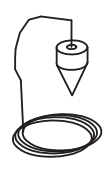
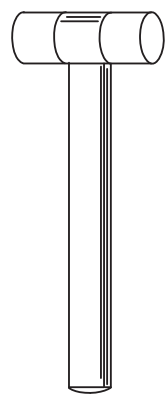
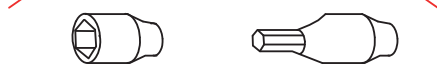
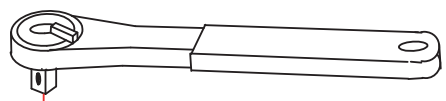
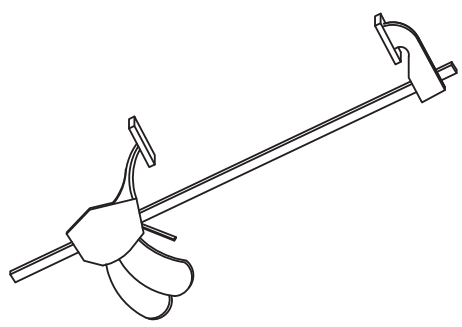
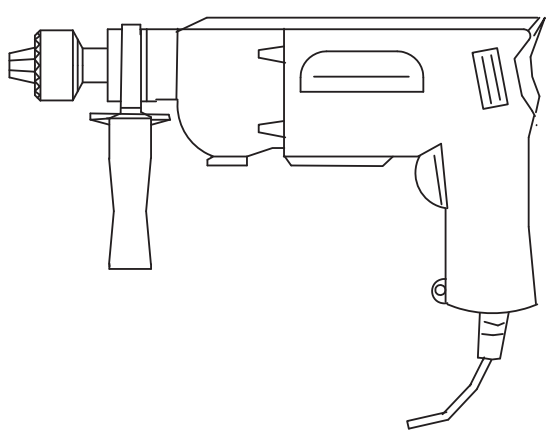
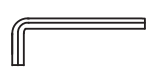
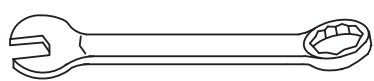
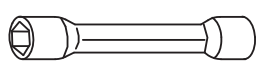
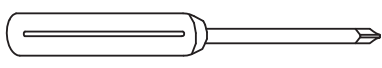
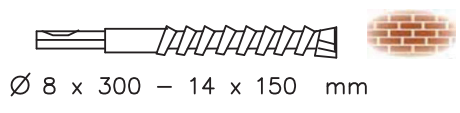
**080**







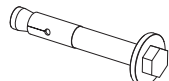






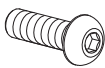

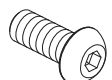
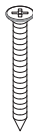
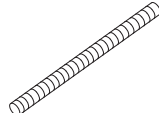





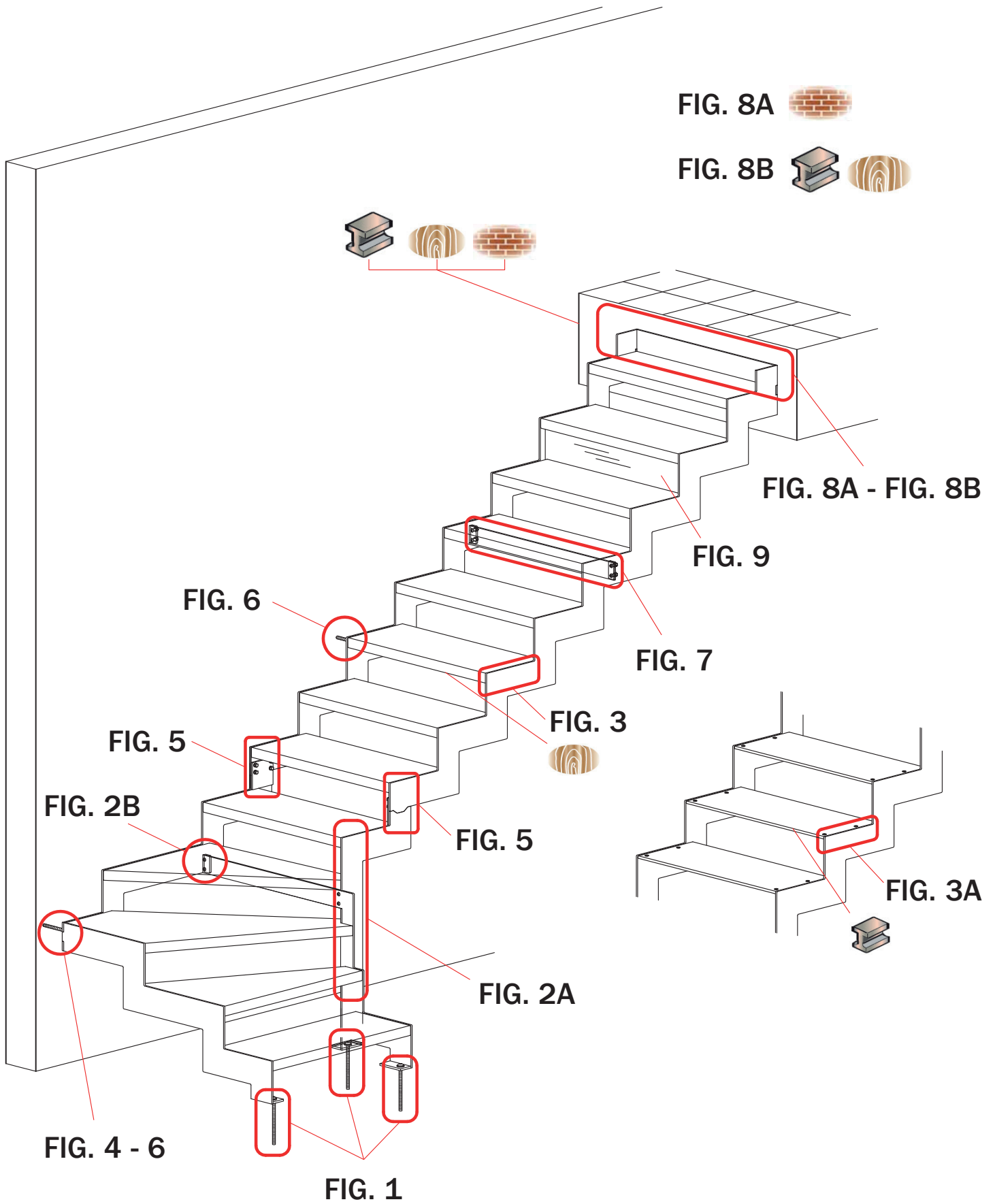
**020 B**



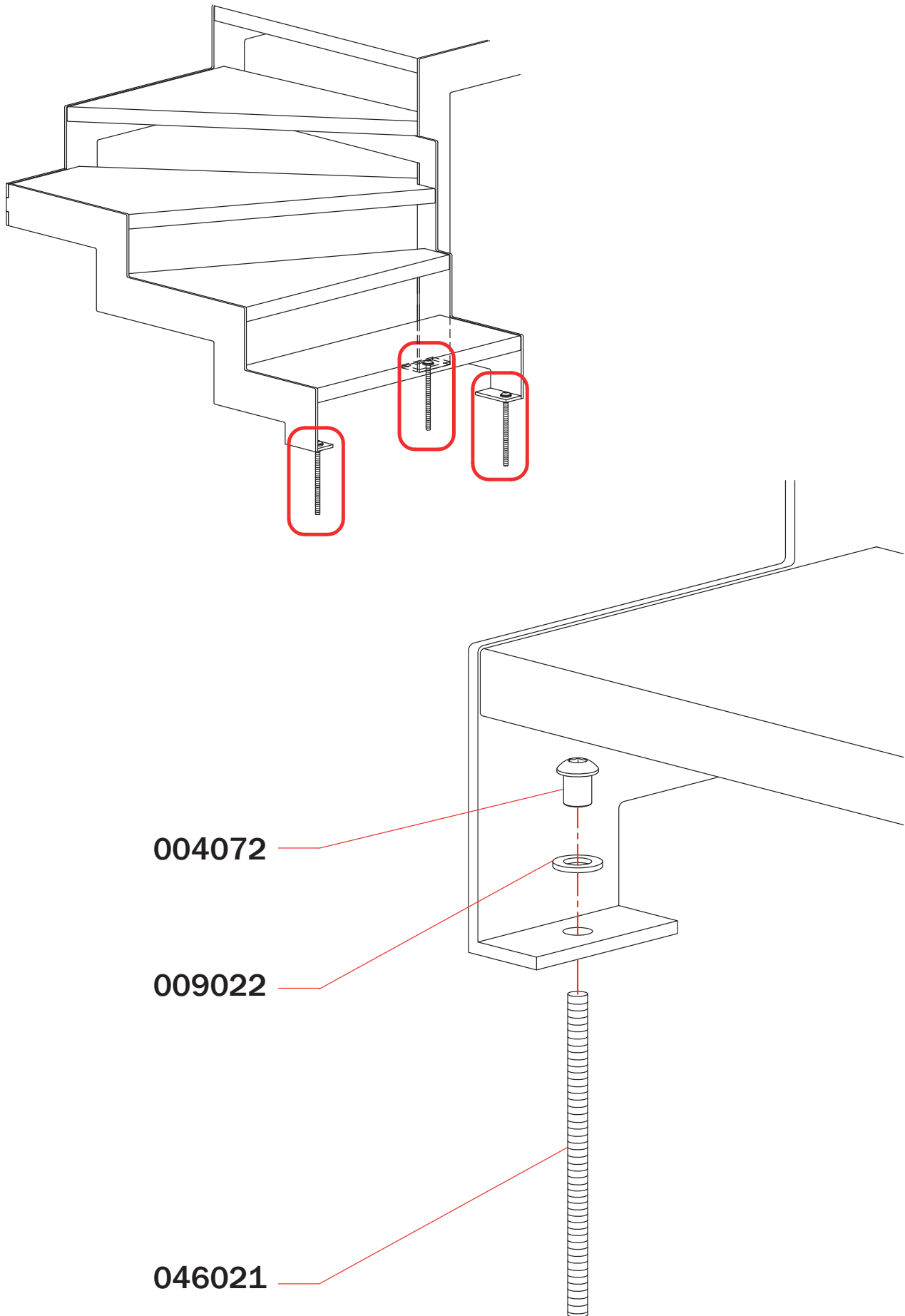
**120 A**



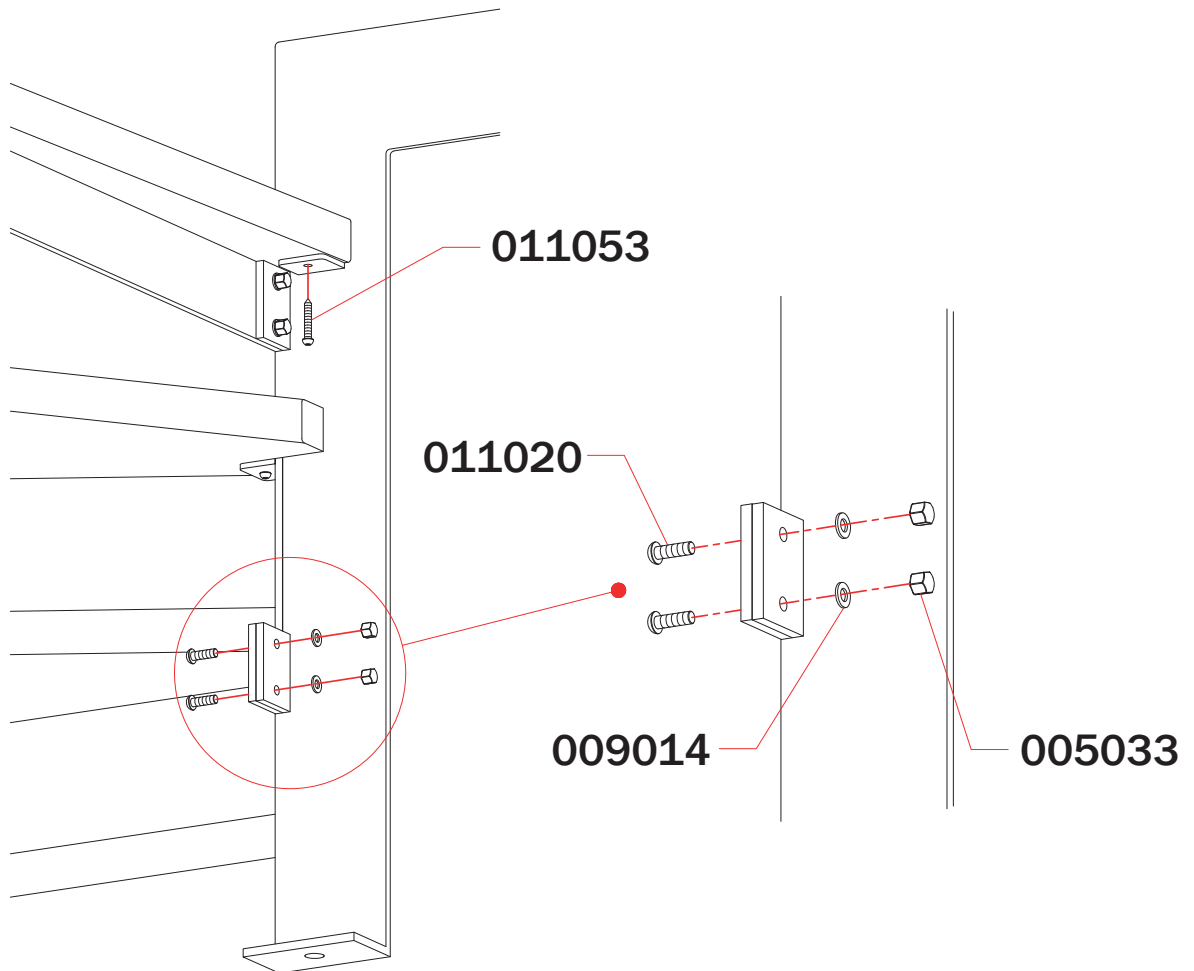
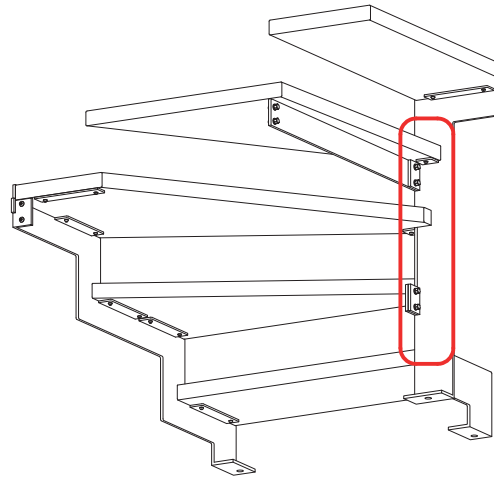
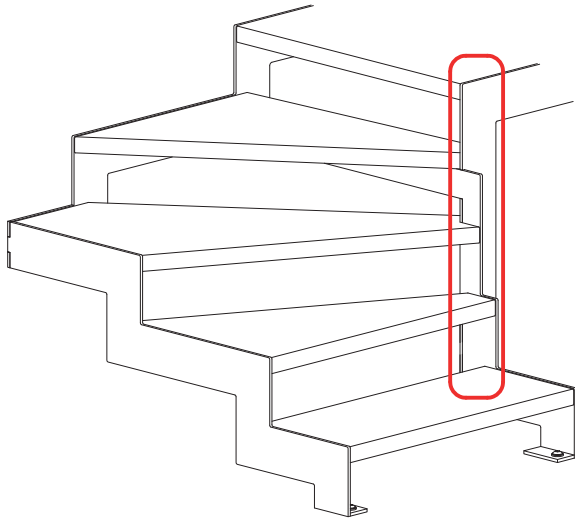
<p>002060</p>  <p>VITE TRUC. TORX TPS 5X35 mm 5X35 mm TPS TORX PLYWOOD SCREW</p>	<p>004028</p>  <p>VITE CANN.M10 X 24 mm M10 x 24mm BOOK SCREW</p>	<p>004069</p>  <p>VITE CANN.M8 X 11,5 mm M8 X 11,5mm BARREL NUT</p>	<p>004072</p>  <p>VITE CANN.M12 X 20 mm M12 X 20mm BARREL NUT</p>	<p>005033</p>  <p>DADO CIECO M8 M8 CAP NUT</p>
<p>005053</p>  <p>DADO CIECO M10 M10 CAP NUT</p>	<p>008020</p>  <p>VITE ESP.18X120 mm 18x120mm EXPAND. SCREW</p>	<p>009012</p>  <p>RANELLA 10 X 21mm 10 X 21mm WASHER</p>	<p>009014</p>  <p>RANELLA 8 X 17 mm 8 X 17 mm WASHER</p>	<p>009019</p>  <p>RANELLA 13 X 24 X 2,5 mm 13 X 24 X 2,5 mm WASHER</p>
<p>009022</p>  <p>RANELLA 17 X 30 X 3 mm 17 X 30 X 3 mm WASHER</p>	<p>011018</p>  <p>VITE TBCE M8 X 20 mm M8 X 20 mm TBCE SCREW</p>	<p>011108</p>  <p>VITE TBCE M8 X 10 mm M8 X 10 mm TBCE SCREW</p>	<p>011020</p>  <p>VITE TBCE M8 X 25 mm M8 X 25 mm TBCE SCREW</p>	<p>011053</p>  <p>VITE TBCE TRUC.6,4 X 40 mm 6,4 X 40 mm TBCE SCREW</p>
<p>011061</p>  <p>VITE T.B.C.E. M12 X 30 mm M12 X 30 mm TBCE SCREW</p>	<p>012014</p>  <p>VITE TRUC. TPS 5X50 mm 5X50 mm TPS PLYWOOD SCREW</p>	<p>046021</p>  <p>MOZZ.FIL. M12 X 200 mm M12X200mm THREAD.L BAR</p>	<p>046056</p>  <p>MOZZ.FIL.LE/FE M 10 X 140 mm M 10 X 140 mm THREADED BAR</p>	<p>130123</p>  <p>DIST.LAT.42x42x205 mm 42x42x205mm LAT. SPACER</p>
 <p>Ø48 mm Ø48 mm</p>				



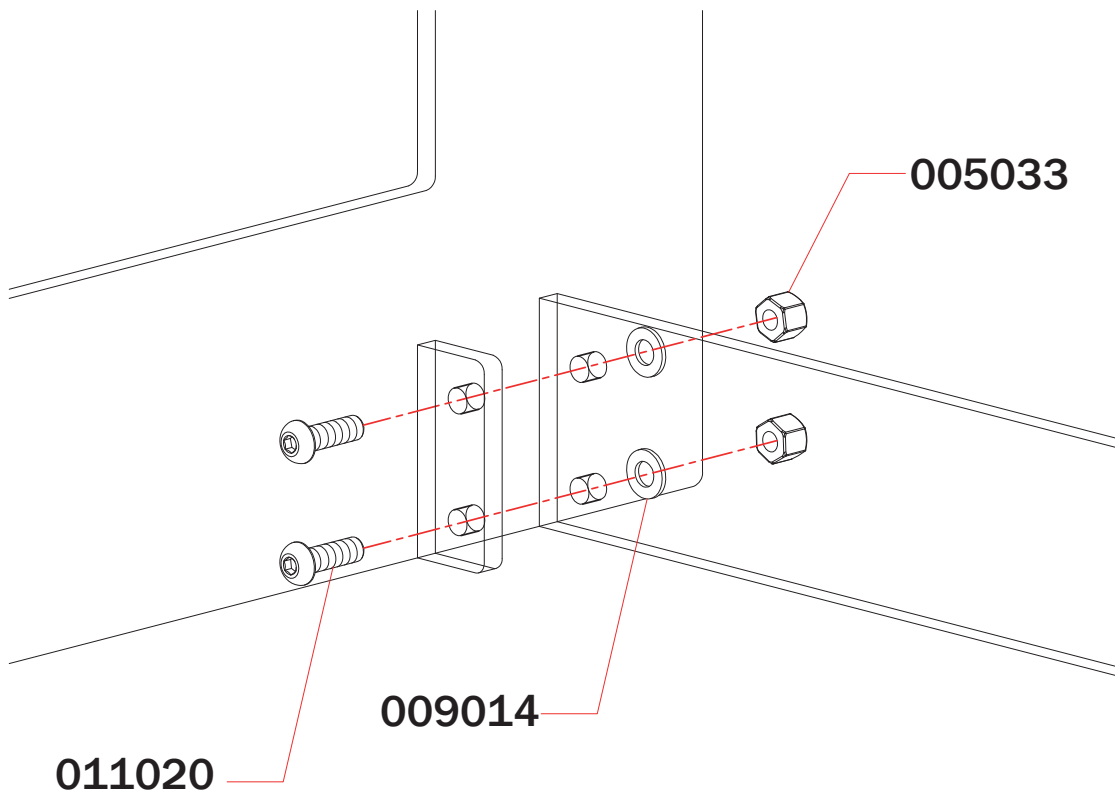
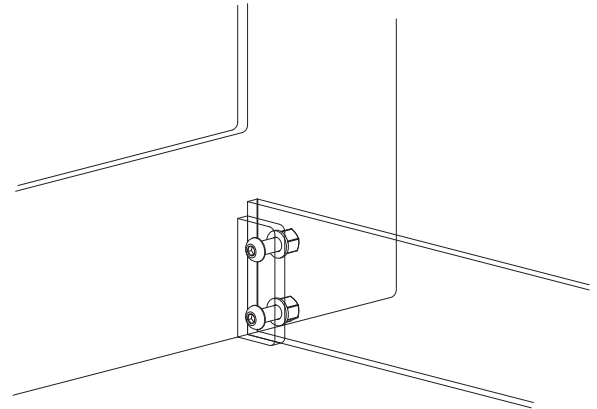
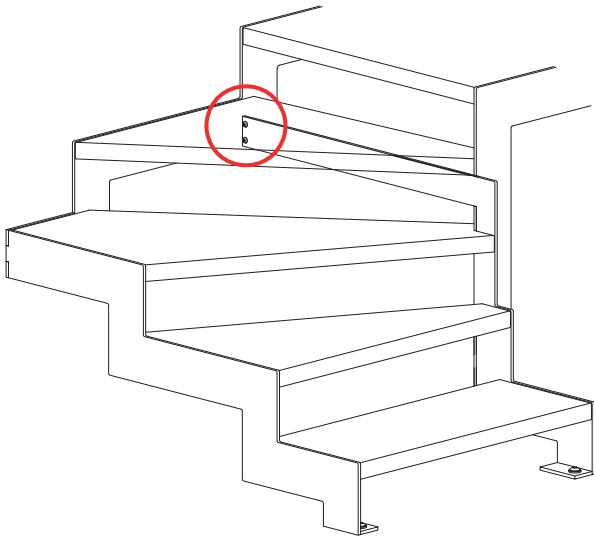
**FIG. 1**



**FIG. 2 A**

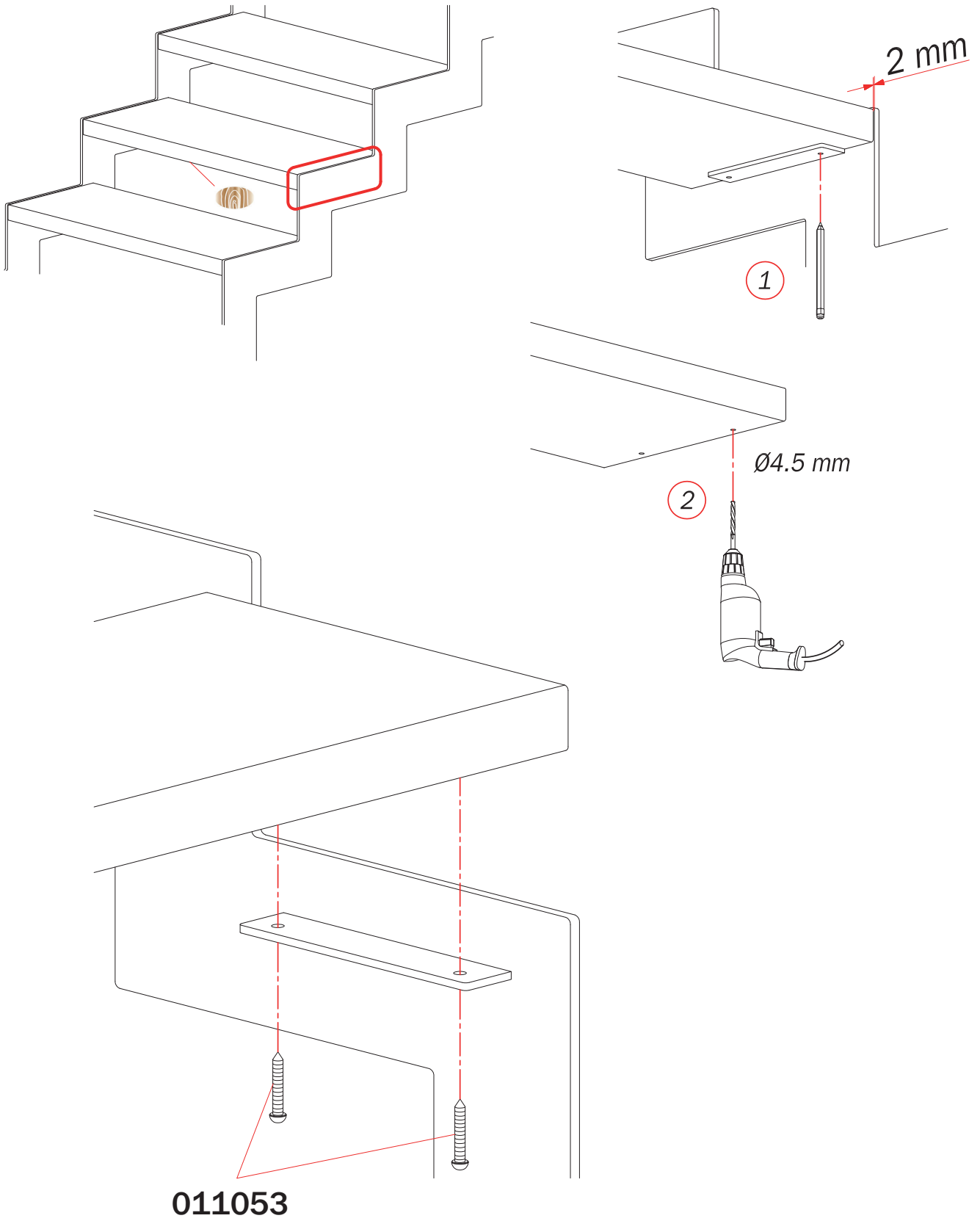


**FIG. 2 B**

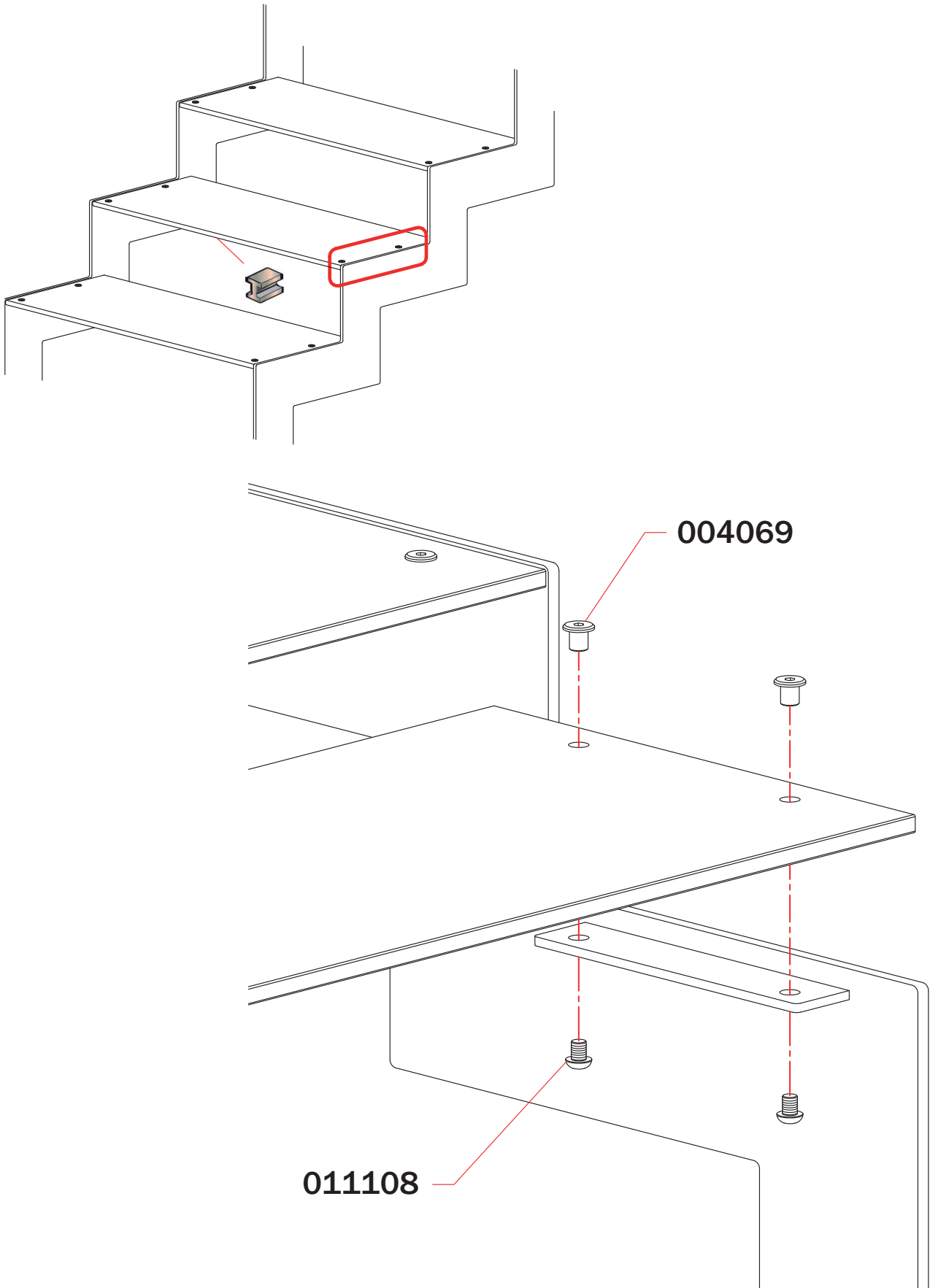




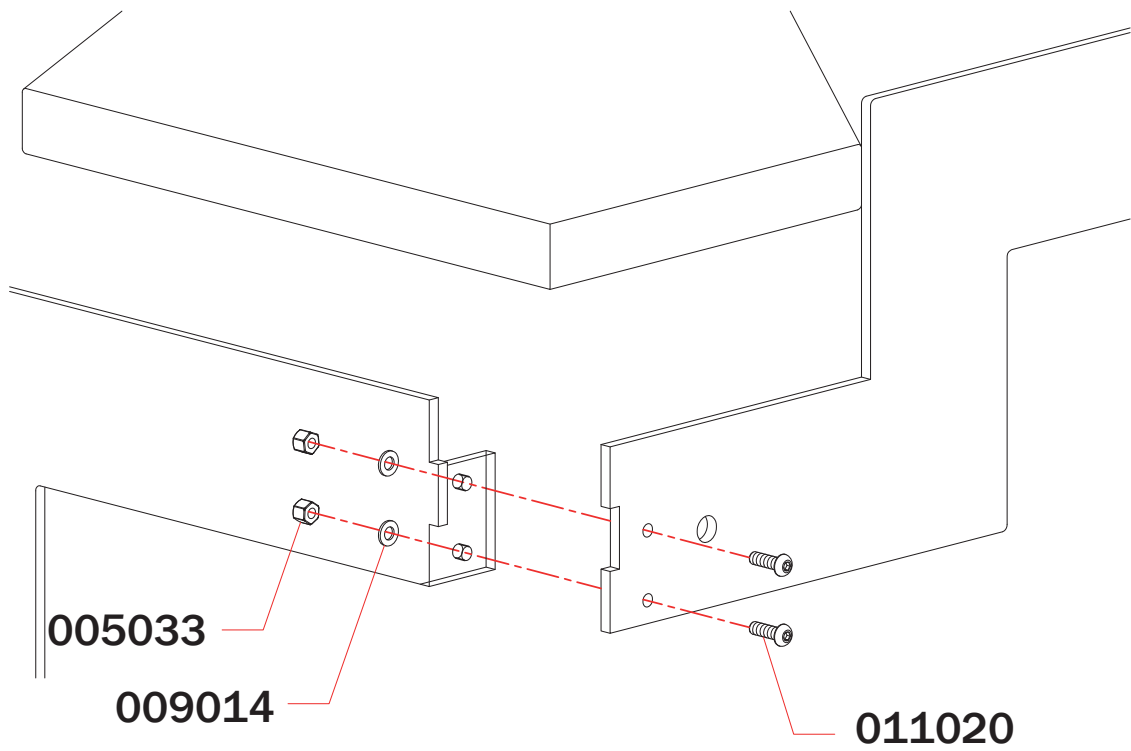
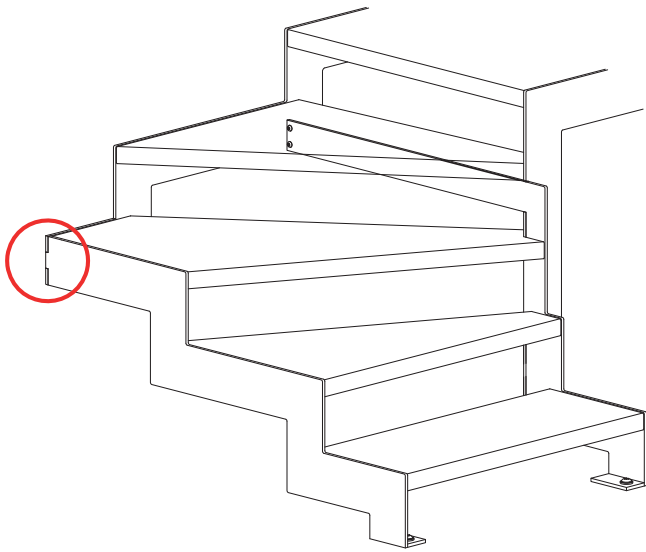
**FIG. 3**



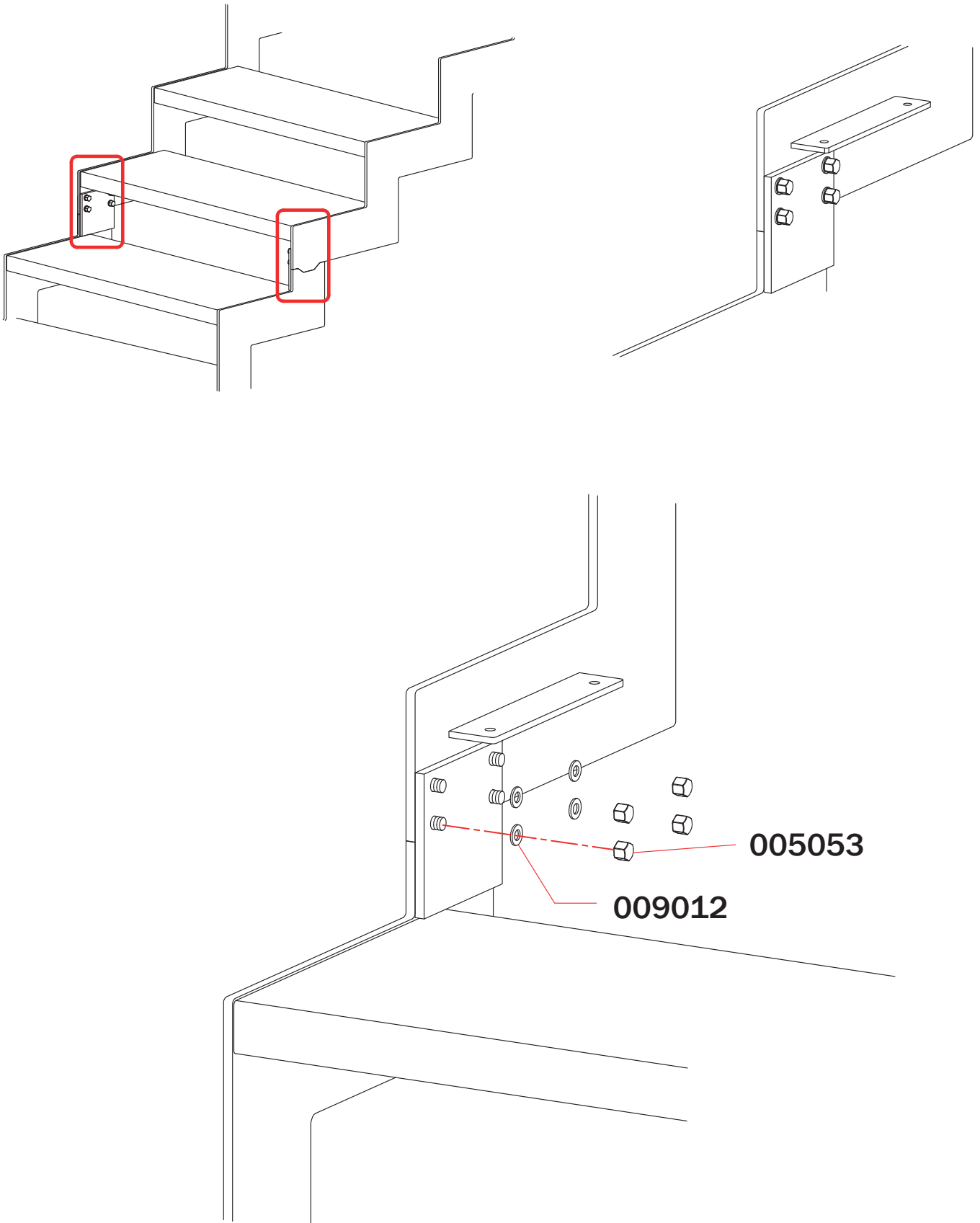
**FIG. 3 A**



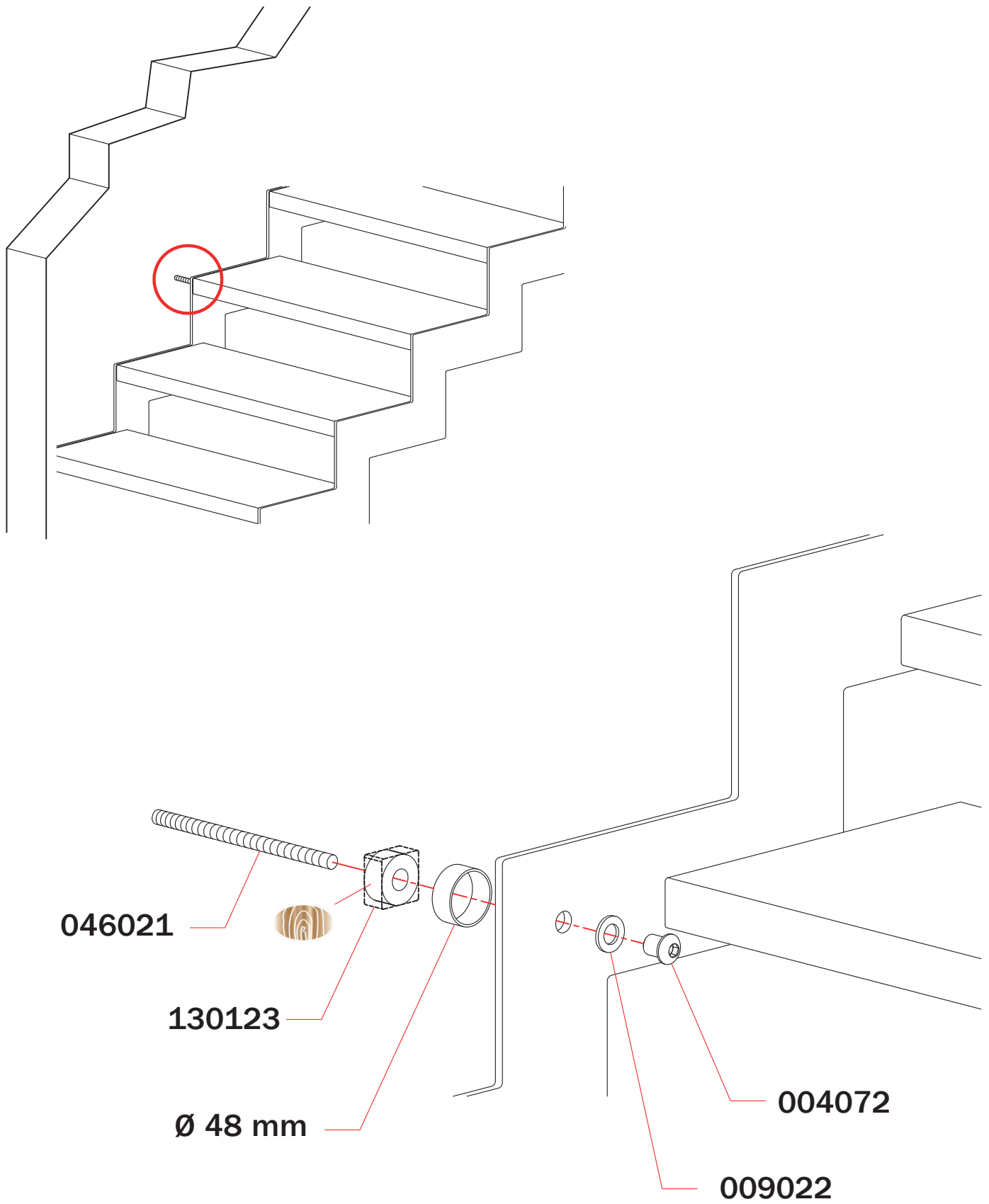
**FIG. 4**



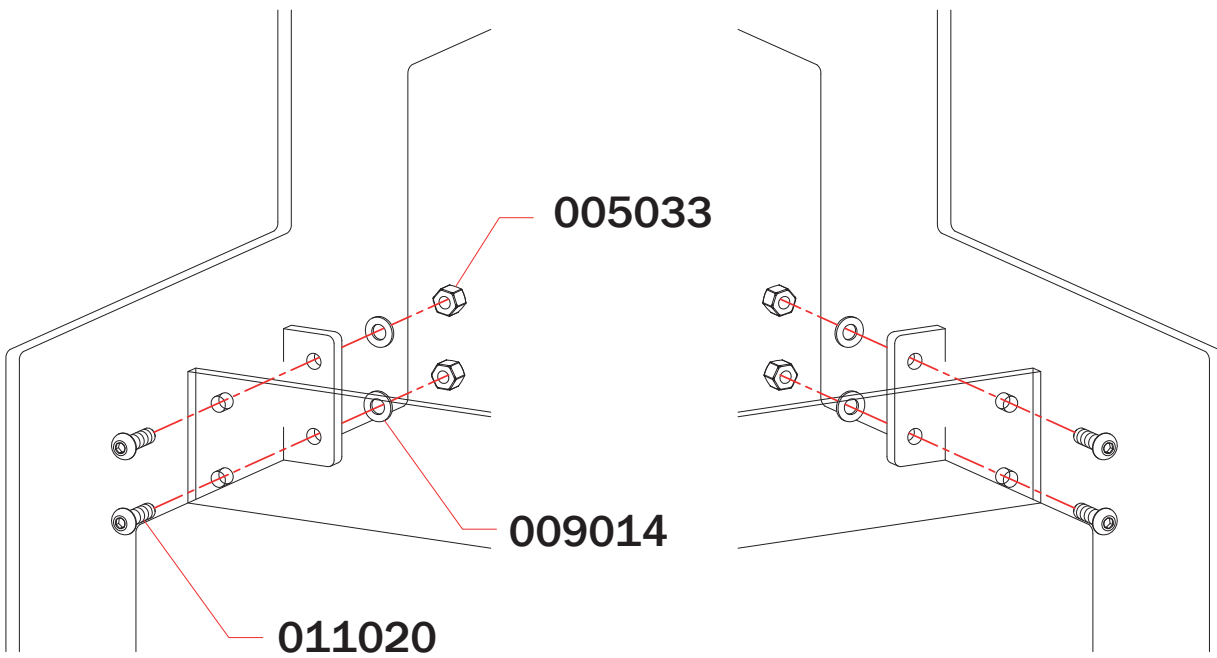
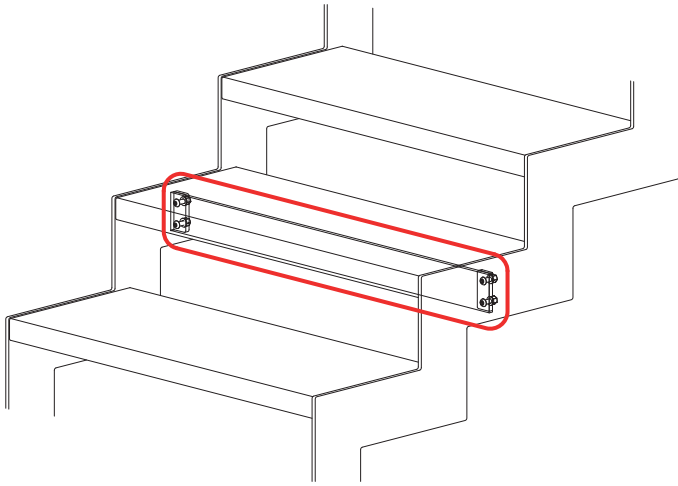
**FIG. 5**



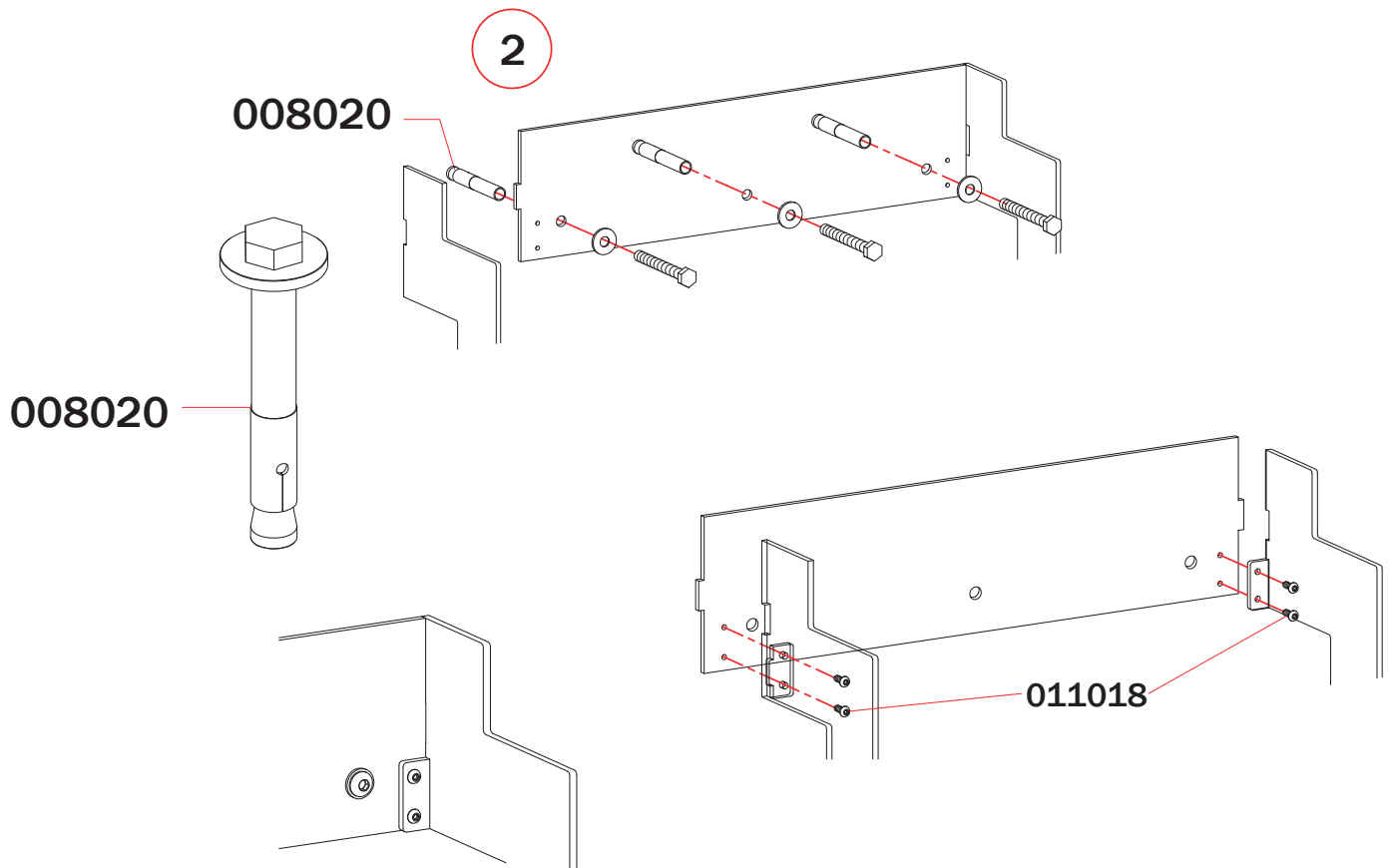
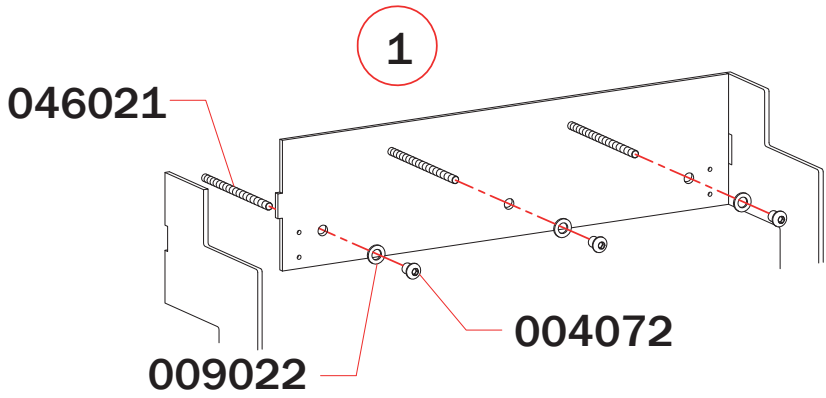
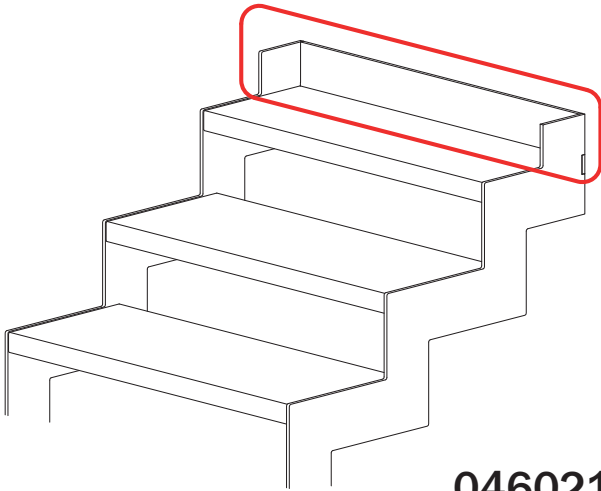
**FIG. 6**



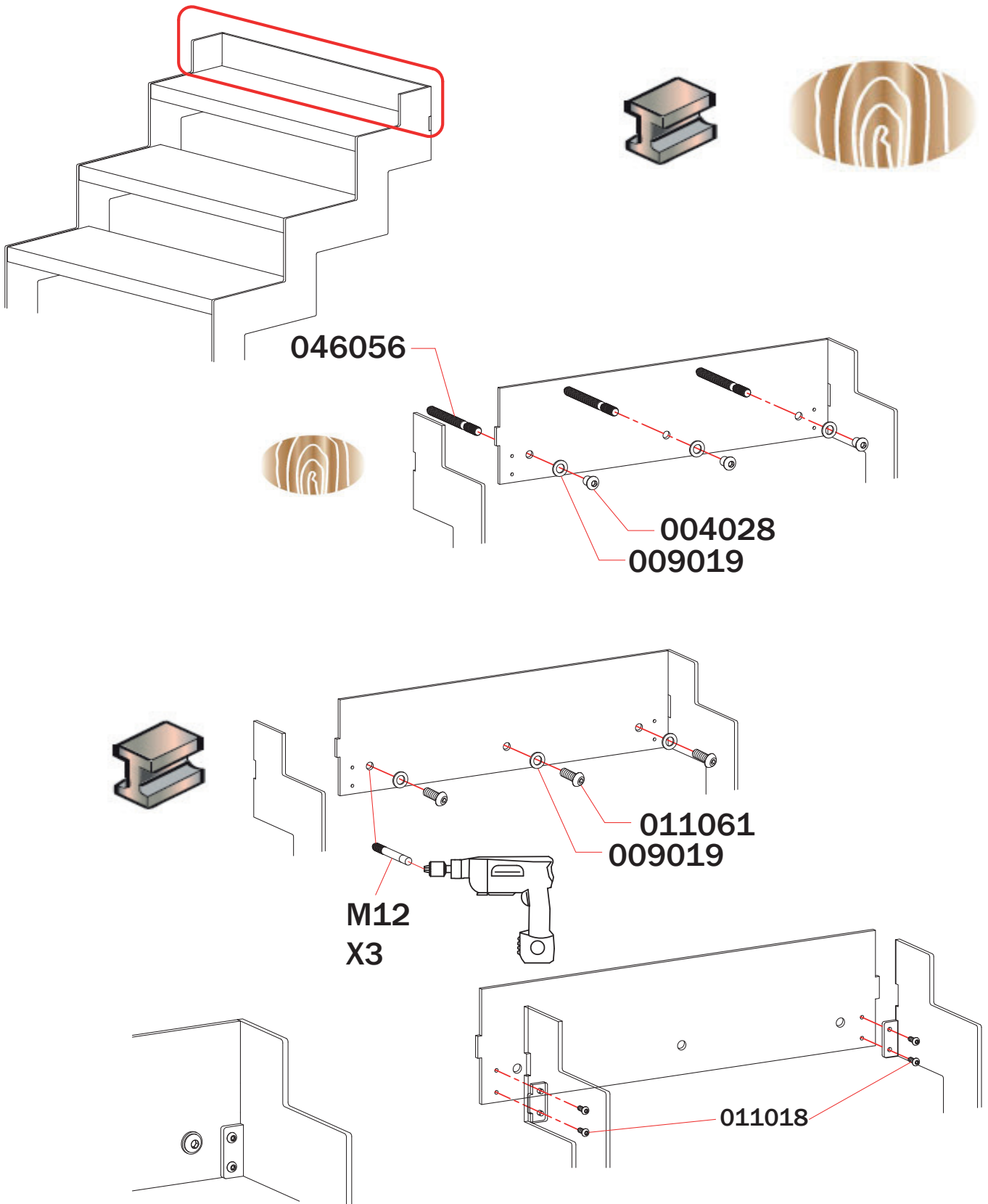
**FIG. 7**



**FIG. 8 A**

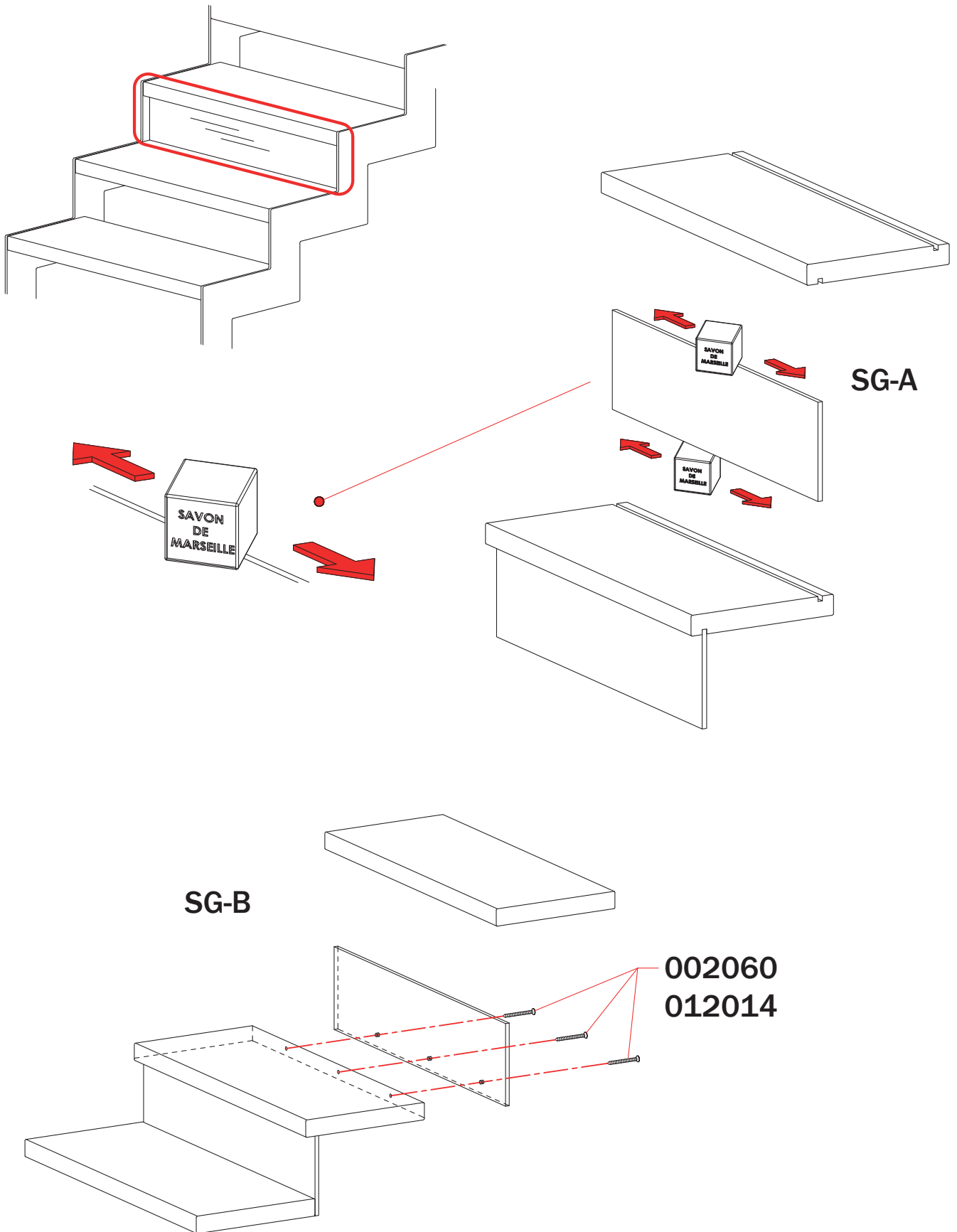


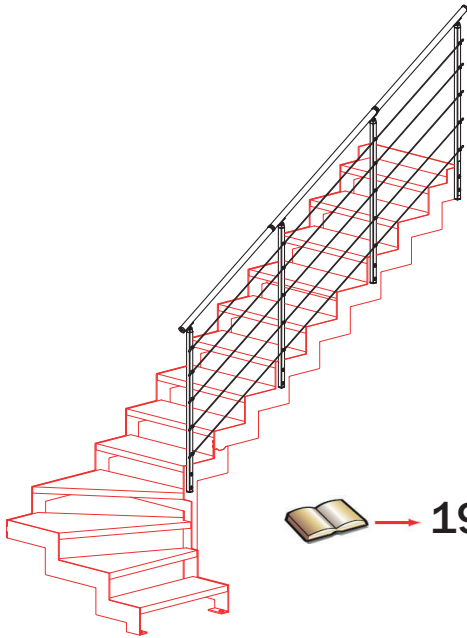
**FIG. 8 B**





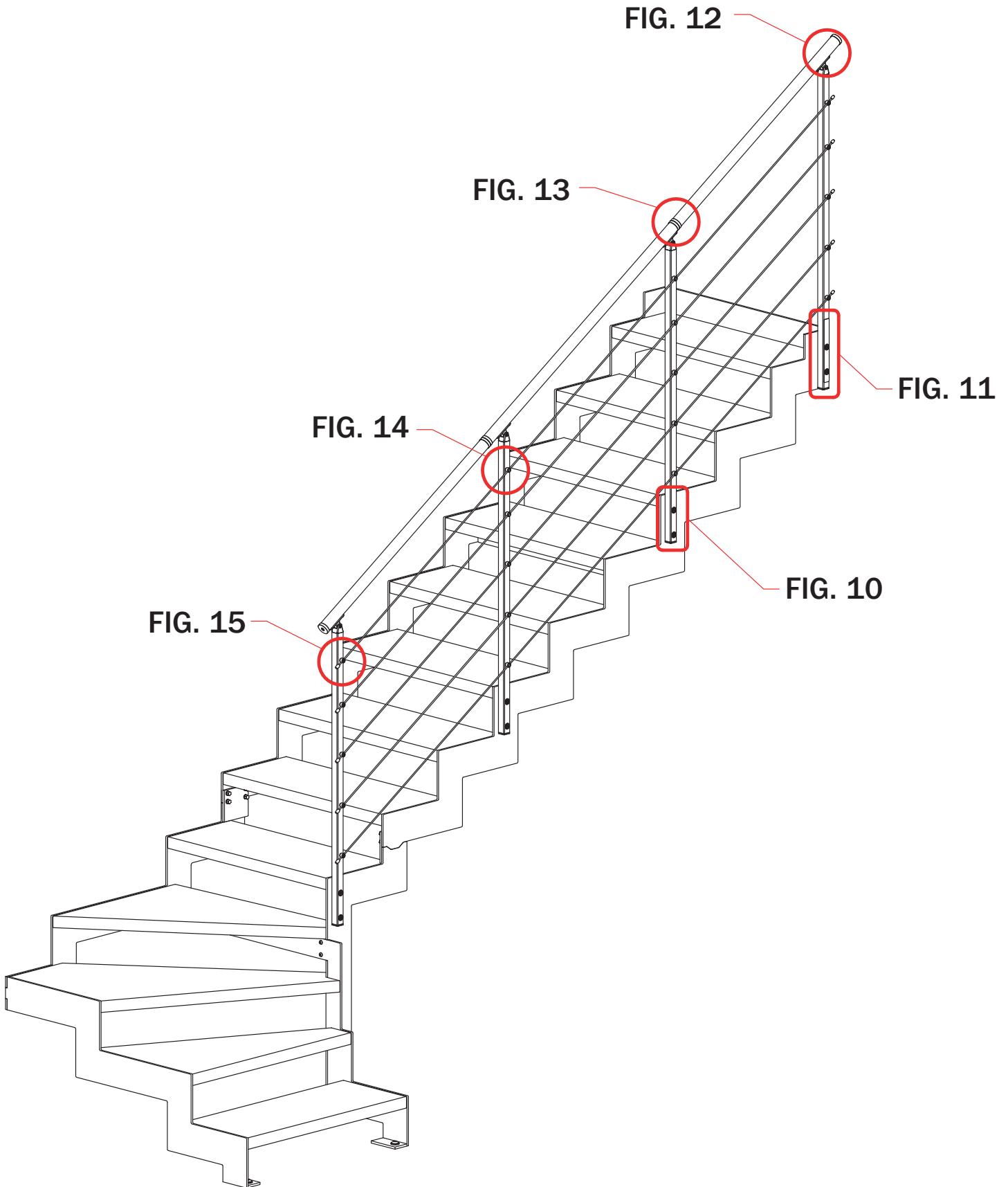
**FIG. 9**







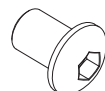







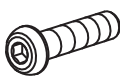
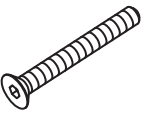
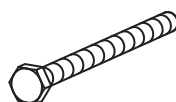









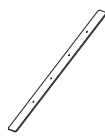
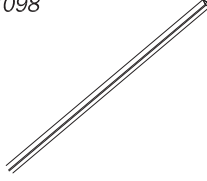
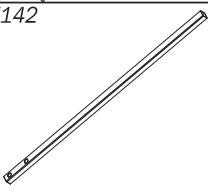
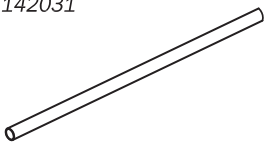




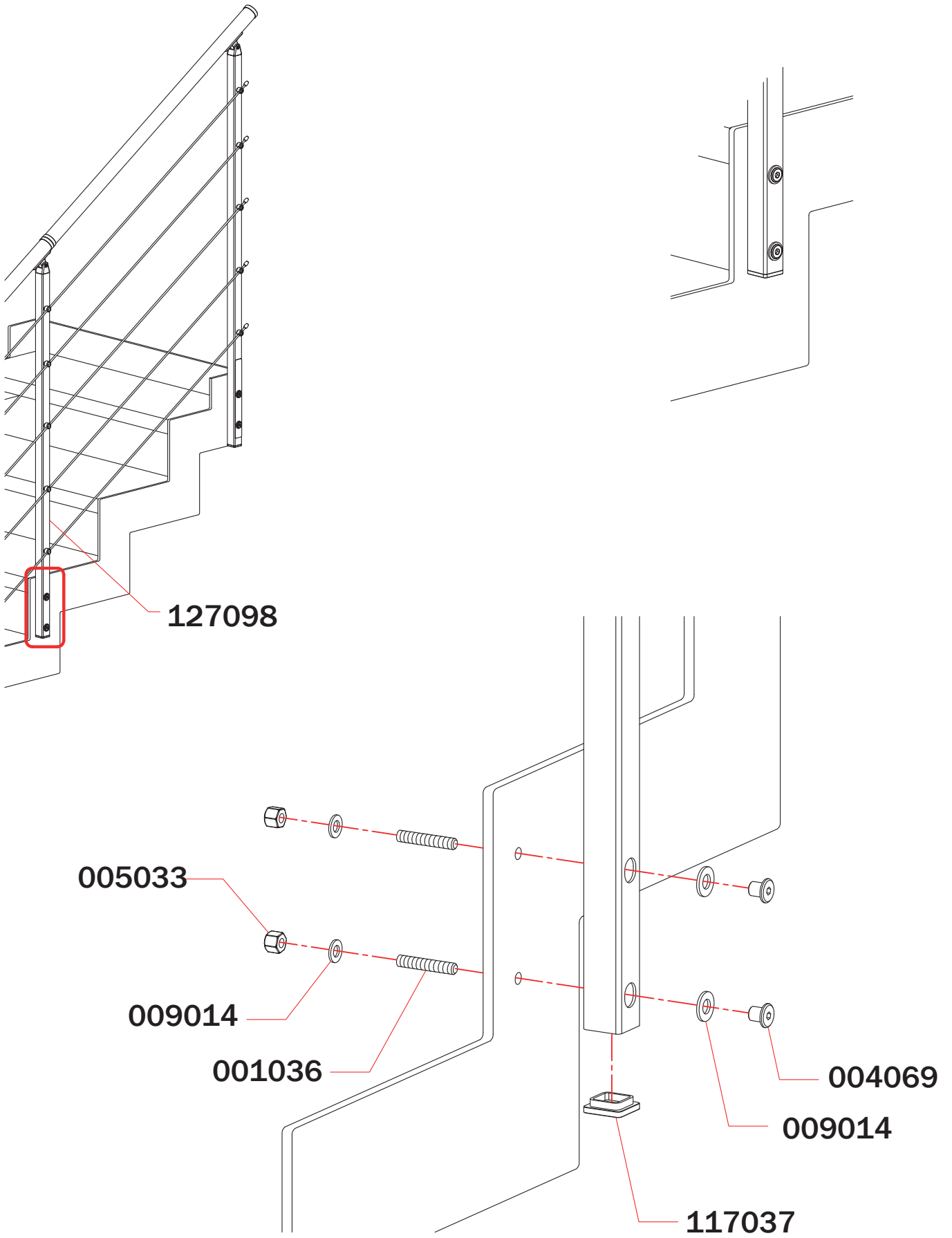
→ 19-27

# 020 A

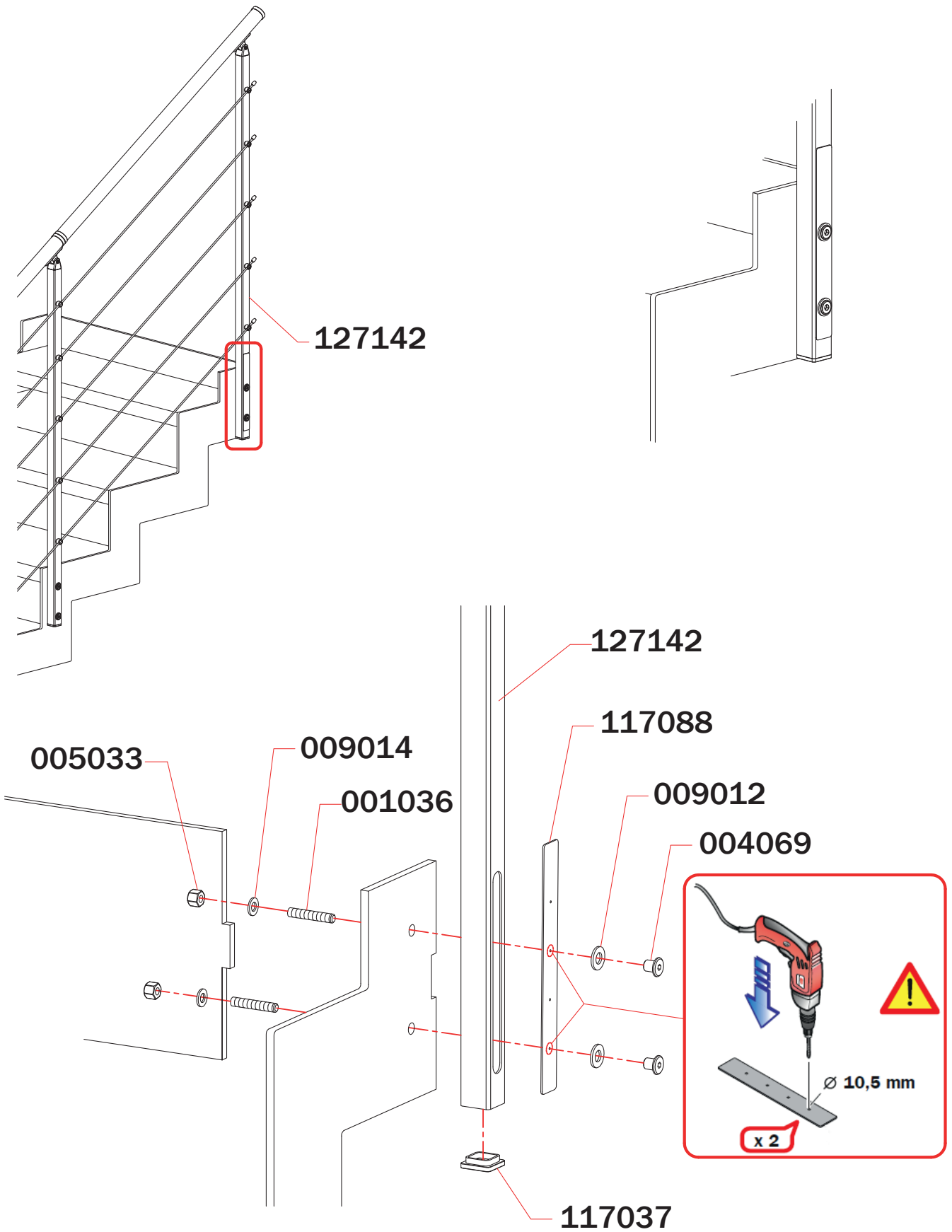


001011  GRANO M4 X 4 P. COPPA Z.B. M4X4 CONV. HEAD GRUB SCR. 002050	001028  SFERA ACCIAIO D. 6,35mm D. 6.35mm STEEL SPHERE 004028	001036  GRANO M8 X 45 P. COPPA Z.B. M8X45 CONV. HEAD GRUB SCR. 004069	001037  GRANO M8 X 25 P. COPPA Z.B. M8X25 CONV. HEAD GRUB SCR. 005011	002024  VITE AUT. T.B. T/C 3,5 X 16 Z.B. T/C 3.5X16 AUTO TH. WHITE SCR. 005033
 VITE PERF. TPS T/C 4,2 X 16 Z.B. T/C 4,2 X 16 TPS PERFOR. SCR. 005035	 VITE CANN. M10 X 24 mm M10 x 24mm BOOK SCREW 009009	 VITE CANN. M8 X 11,5 mm M8 x 11,5 mm BOOK SCREW 009012	 DADO M8 Z.B. M8 WHITE ZINK NUT 009014	 DADO CIECO M8 M8 CAP NUT 011088
 DADO M6 N.O. M6 OPAQUE NICHEL NUT 013030	 RANELLA 15 X 28 X 2.5mm 15X28X2.5mm WASHER 013031	 RANELLA 10 X 21mm 10 X 21mm WASHER 031098	 RANELLA 8 X 17 mm 8 X 17 mm WASHER 031168-031170-031172	 VITE TBCE M6 X 25 Z.B. M6X25 TBCE WHITE ZINK SCR. 031169-031171-031175
 VITE TPSEI M6 X 50 Z.B. TPSEI M6X50 WHITE ZINK SCR. 033355	 VITE T.E. M8 X 100mm Z.B. M8X100mm T.E. Z.K WH. SCREW 034041	 FERMO CILINDRO PASSA CAVO CYLINDER CABLE HOLDER 034042	 UNIONE CORRIM. D.40 X 1,5 D.10X1.5 HANDRAIL JOINT 034056	 CONO ESPAN. CORR. D.40 X 1,5 D.40X1.5 HANDR. EXPAND. CONE 046015
 STAFFA FISS. CORRIM. D.40 D.40 HANDRAIL, FAST. BRACKET 117037	 CILINDRO PASSA TONDINO BAR FASTENING CYLINDER 117088	 FINALE PROTEZIONE CAVO CABLE END PROTECTION 127098	 CAPP. PALETTO QUADRO 30 X 30 30X30 SQ. BALUST. UPPER FAST. 127142	 MOZZ. FIL. LE/FE M 8 X 80 mm M 8 X 80 mm THREADED BAR 142031
 TAPPO INF. PALETTO 30 X 30 30X30 BALUST. LOWER CAP	 PIASTRINO COPRI ASOLA LOOP COVER PLATE	 PALETTO 30X30 H1065 30X30 H1065 BALUSTER	 PALETTO 30X30 H1145 30X30 H1145 BALUSTER	 CORR. METALLO D.40 L.1185 D.40 L.1185 METAL HANDRAIL

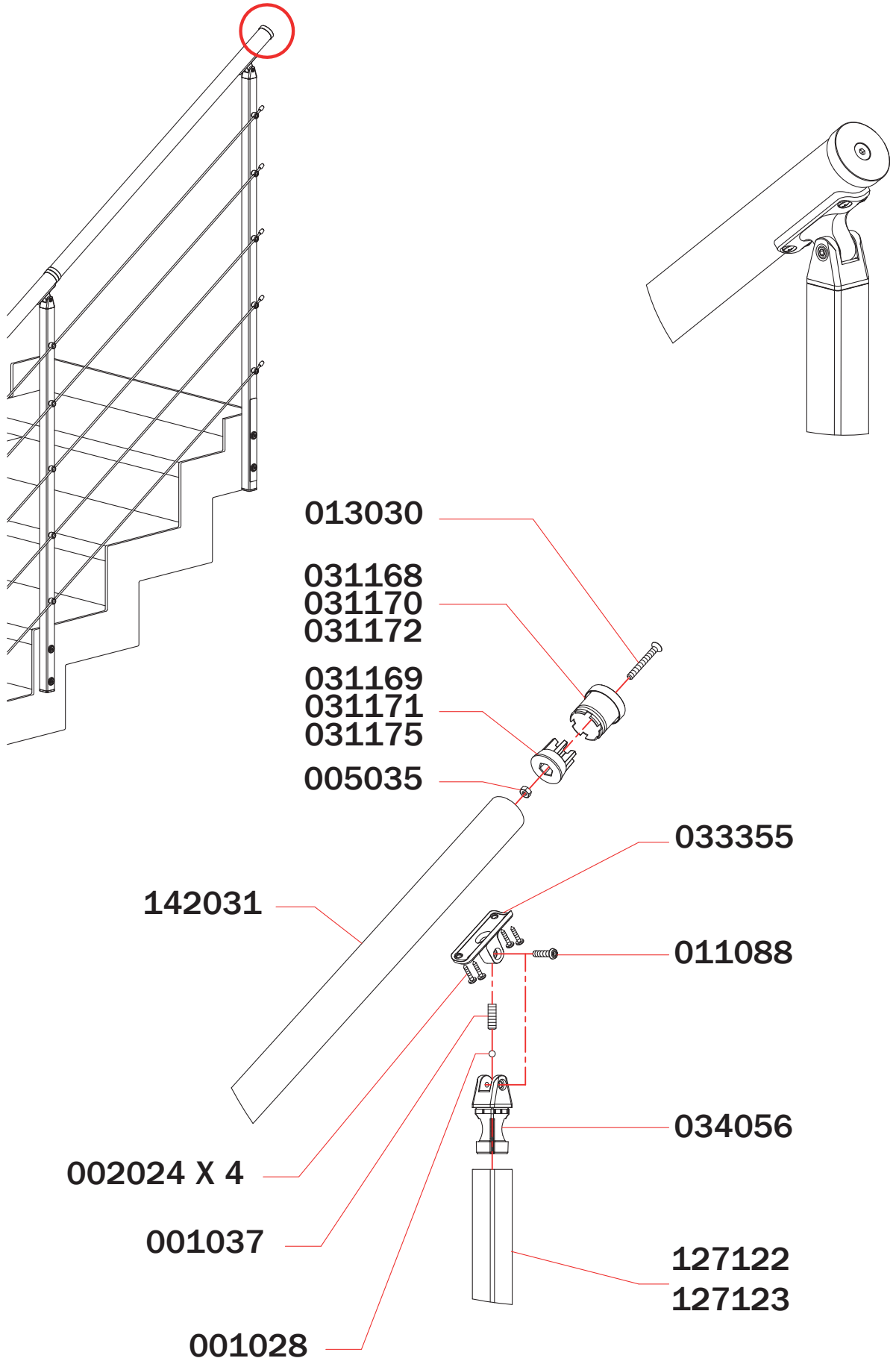
**FIG. 10**



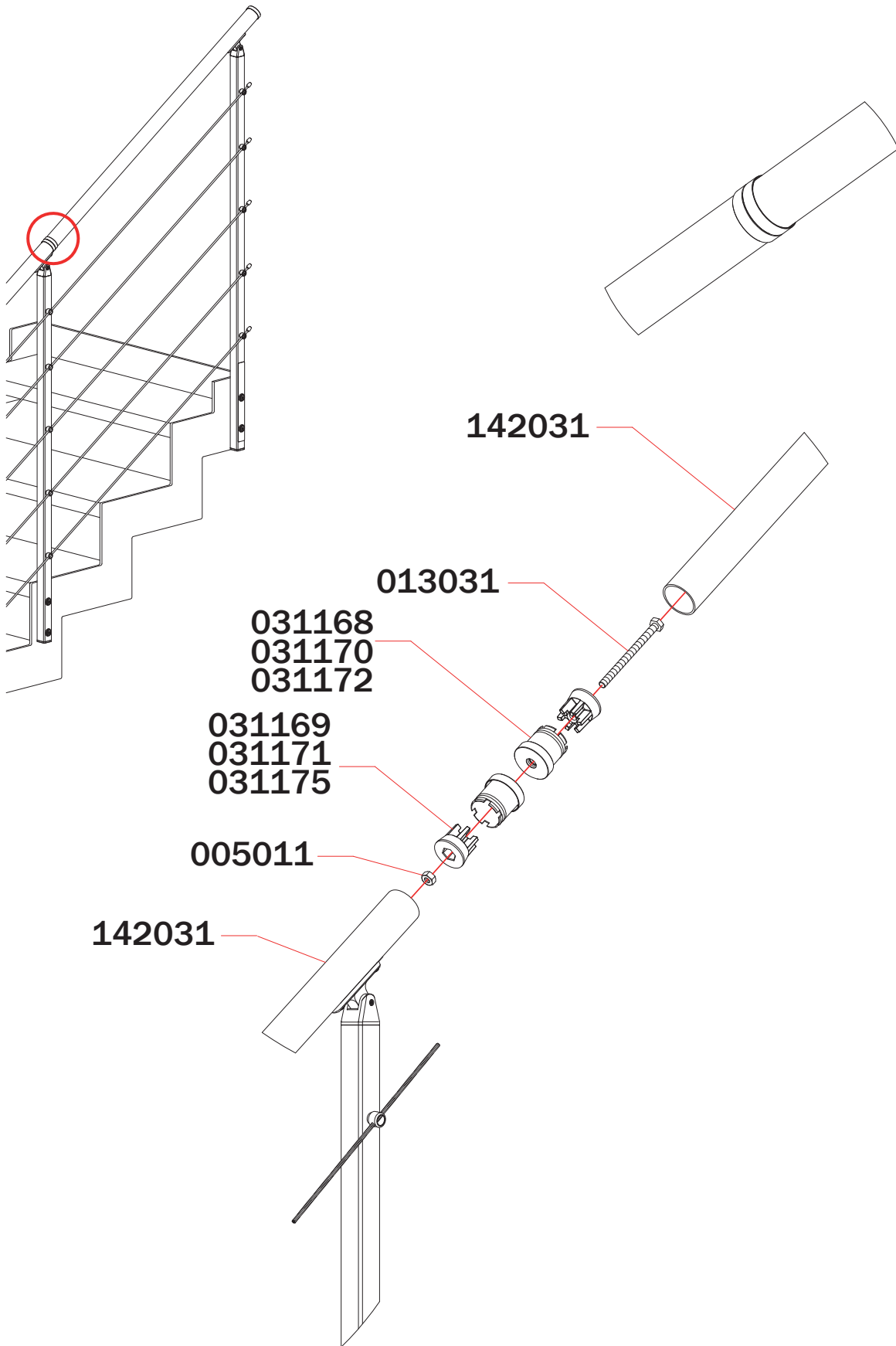
**FIG. 11**



**FIG. 12**

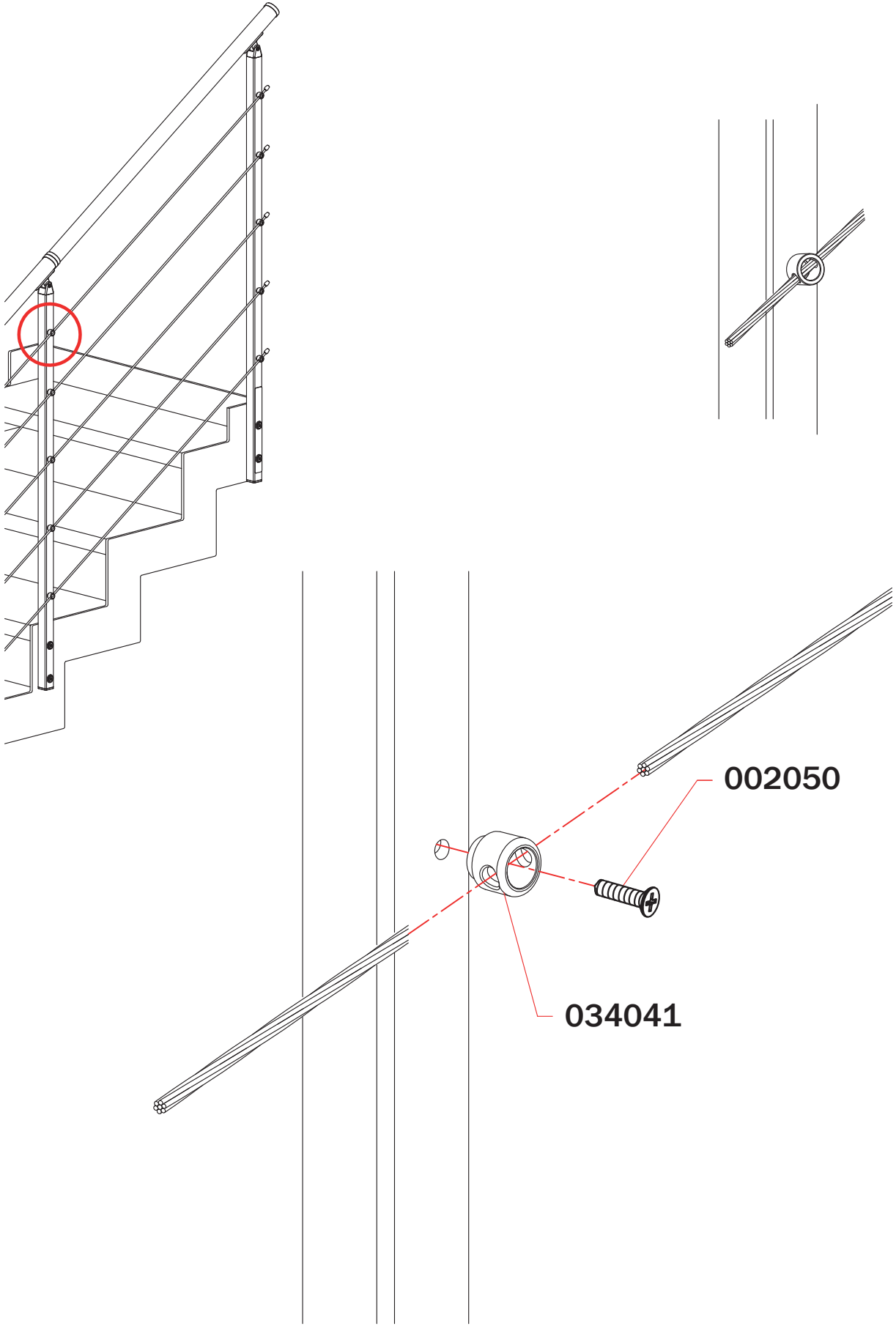


**FIG. 13**





**FIG. 14**



**FIG. 15**

